



Upgrade Guide SAP SCM 7.0 EHP1 – Standalone Engine SAP liveCache Technology 7.7: Windows

Target Audience

- Technology Consultants
- System Administrators

PUBLIC

Document version: 1.0 – 2011-03-24

Document History



CAUTION

Before you start the implementation, make sure you have the latest version of this document.

You can find the latest version on SAP Service Marketplace <http://service.sap.com/>

[instguides](#).

The following table provides an overview on the most important document changes:

Version	Date	Description
1.0	2011-03-24	Initial Version

Table of Contents

Chapter 1	Introduction	<u>5</u>
1.1	Before You Start	<u>5</u>
1.1.1	SAP Notes for the Upgrade	<u>5</u>
1.1.2	More Information on SAP Service Marketplace	<u>6</u>
1.1.3	Naming Conventions	<u>6</u>
Chapter 2	Planning	<u>7</u>
2.1	Checking Software Requirements	<u>7</u>
2.2	Choosing an Upgrade Strategy	<u>7</u>
2.3	Identifying the Correct Source of the New liveCache Software	<u>8</u>
Chapter 3	Preparation	<u>11</u>
3.1	Completing the Upgrade Preparations	<u>11</u>
Chapter 4	Upgrading liveCache	<u>13</u>
Chapter 5	Post-Upgrade	<u>15</u>
5.1	Performing Post-Upgrade Activities	<u>15</u>
5.2	Setting Up a liveCache Super User	<u>17</u>
5.3	Installing or Upgrading Database Studio for SAP MaxDB	<u>17</u>
Chapter 6	Additional Information	<u>21</u>
6.1	Operating Information for liveCache	<u>21</u>
6.2	Secure Sockets Layer Protocol for Database Server Communication	<u>21</u>
6.2.1	Installing the SAP Cryptographic Library	<u>21</u>
6.2.2	Generating the Personal Security Environment	<u>23</u>
6.3	Database Directory Structure	<u>25</u>
6.4	Sample Directory Structure	<u>26</u>
6.5	Log Files for Troubleshooting	<u>27</u>

**This page is left blank for documents
that are printed on both sides.**

1 Introduction

This documentation describes how to upgrade an SAP liveCache instance from at least Release 7.5 to Release 7.7. SAP liveCache is used in SAP Supply Chain Management (SCM).



CAUTION

Make sure you have the **latest version of this document**. See the version number on the front page. You can always find the latest version at:

▶ <http://service.sap.com/instguides> → *SAP Business Suite Applications* → *SAP SCM* → *SAP SCM Server* → *Using SAP enhancement package 1 for SAP SCM Server 7.0* ◀

For more information about SAP SCM technology, see:

▶ <http://service.sap.com/scm> → *Technology* ◀

1.1 Before You Start

Make sure that you read the following sections before you start the upgrade:

- *SAP Notes for the Upgrade* [page 5]
- *Information Available on SAP Service Marketplace* [page 6]
- *Naming Conventions* [page 6]

1.1.1 SAP Notes for the Upgrade

Read the following SAP Notes, which you can find at <http://service.sap.com/notes>:

Note Number	Title
1072392	Enhancements to the upgrade to liveCache 7.7
498036	Overview note: Importing MaxDB/liveCache versions
833216	Parameter values as of liveCache versions 7.5, 7.6 and 7.7
337445	liveCache and Memory Management
508979	Upgrade of SAP DB/MaxDB/liveCache w/ Cluster MSCS Var.1
487972	Operating system parameterization of liveCache



CAUTION

Before you begin the upgrade, make sure that you read **SAP Note [1072392](#)** because it contains current information and corrections essential to the upgrade.

1.1.2 More Information on SAP Service Marketplace

You can find more information on SAP Service Marketplace as follows:

Description	Address
liveCache Upgrade Guide	▶ http://service.sap.com/instguides → SAP Business Suite Applications → SAP SCM → SAP SCM Server → Using SAP enhancement package 1 for SAP SCM Server 7.0 ◀
Product Availability Matrix (PAM)	http://service.sap.com/pam
SAP Notes	http://service.sap.com/notes

1.1.3 Naming Conventions

Release Names

Where release descriptions are used in the following documentation, they correspond to the following SAP SCM Releases:

Release of SAP Web Application Server or SAP NetWeaver	Release of SAP SCM
6.40	4.1
7.0	5.0, 2007 (5.1)
7.01	7.0
7.02	7.01

SAP System

The SAP system name is called SAPSID below. Follow the notation in pointed brackets. If <SAPSID> is used, insert your SAP system name, for example PRD.

<SAPSID> User Name

The user name is written in uppercase and abbreviated with <SAPSID>ADM.



CAUTION

Always enter the user name <sapsid>adm in lowercase for the standalone database server.

liveCache Application Routines

The liveCache application routines are called “liveCache applications”. The application area is BC-DB-LCA, where the abbreviations have the following meanings:

- BC means Basis components
- DB means database
- LCA means liveCache applications

2 Planning

To plan the upgrade, you need to do the following:

1. You *check the software requirements* [[page 7](#)].
2. You *choose an upgrade strategy* [[page 7](#)].
3. You *identify the correct source of the New liveCache software* [[page 8](#)].

2.1 Checking Software Requirements

Procedure

1. Check that:
 - SAP liveCache is ready to run.
 - The system tables have been loaded at least once for the existing instance.
 - The database parameters of the database instance that you want to upgrade have not changed since the last restart.
 - The starting version of SAP liveCache (that is, before the upgrade) is at least 7.5.
2. Check your operating system release.

For the most up-to-date release information on the database and operating system of your product, check the SAP Product Availability Matrix (PAM) as follows:

1. Go to <http://service.sap.com/pam>.
2. Choose *Start PAM with navigation by category*.
3. On the right-hand panel, choose ► *SAP Application Components* → *SAP SCM* → *SAP SCM <Release>* → *Operating Systems* → *SAP liveCache* ◀.
4. Click the red exclamation mark in column *Remarks* to see the number of the note with additional information on required operating system patch levels and patches for C++ RTE.

For additional operating system requirements, see the following SAP Notes:

- [337445](#) *liveCache and Memory Management*
- [487972](#) *Operating System Parameterization of liveCache*

You can find these notes at:

<http://service.sap.com/notes>

2.2 Choosing an Upgrade Strategy

The upgrade strategy you choose depends on your existing release of SAP liveCache, your start release, and your target release of the SAP system.

Prerequisites

The upgrade strategies differ as follows:

- Inplace upgrade
Inplace upgrade does not change the structure, as occurs when the start and target releases for the SAP system or the SAP liveCache database are different. Therefore, only the SAP liveCache software is updated during an inplace upgrade.
- SCM Extract / Load Upgrade
With the SCM extract / load upgrade, transaction data is backed up using ABAP reports during the SCM system upgrade, that is, **before** the SAP liveCache upgrade. This type of upgrade overwrites data files and devspaces from SCM Release 4.1, 5.0, or 5.1 during the installation of the new SAP liveCache software. You do not need to first deinstall anything. Finally, the SAP liveCache instance is recreated and initialized.



NOTE

SCM Release 4.0 is **not** supported as a start release for the upgrade.



CAUTION

Use the SCM extract / load upgrade strategy **only** for an SCM upgrade to 7.0 EHP1.

Procedure

Choose your upgrade strategy in one of the following ways:

- Follow the instructions in the relevant SAP system upgrade documentation.
- Use the tables below to determine your upgrade strategy.

SAP liveCache Upgrade During an SCM Upgrade

SCM Start Releases	SCM Target Release	SAP liveCache Kernel Start Release	Upgrade Strategy
4.1, 5.0, 2007 (5.1)	7.0 EHP1	>=7.5	SCM extract / load upgrade

SAP liveCache Upgrade Without an SAP System Upgrade

SAP liveCache Kernel Start Release	SAP liveCache LCA Start Release	Upgrade Strategy
7.7	7.0	Inplace upgrade

2.3 Identifying the Correct Source of the New liveCache Software

You need to identify whether you can use the liveCache software on the liveCache DVD in the SCM 7.0 package or whether you must use the most up-to-date liveCache software from the Software Distribution Center (SWDC) on SAP Service Marketplace.

Procedure

- If you are using SCM 5.0 or lower, you can use the liveCache DVD in the SAP SCM 7.0 EHP1 package.

2.3 Identifying the Correct Source of the New liveCache Software

- If you are using SCM 5.1 where the liveCache major version is already 7.7 and if your starting version – in terms of package level and patch level – of SAP liveCache (that is, before the upgrade) is already **higher** than the liveCache version on the DVD, you must use the most up-to-date liveCache software from the SWDC.

You can find your current version of liveCache with the following command:

```
dbmcli -d <LCSID> -u control,<control_password> show version
```

You can find the DVD versions in SAP Note [1072392](#) or by entering the following command with the mounted liveCache DVD:

```
<DVD dir>/DATA_UNITS/LC_<OS>/SDBINST -1
```

If you use the command, check the database kernel version shown in the command output with your current version of liveCache.

You can download and unpack the liveCache software from the SWDC here:

► <http://service.sap.com/swdc> → Support Packages and Patches → A-Z Index → S → SAP SCM → SAP SCM 7.0 → Entry by Component → SAP liveCache → SAP LC/LCAPPS 7.0 → <OS> ◀

You can also find information about the availability of liveCache versions in SCM 7.0 EHP1 here:

► <http://www.sdn.sap.com/irj/sdn/livecache> → SCM 7.0 ◀

**CAUTION**

If there is no equivalent or higher SAP liveCache version available at the SWDC, you **cannot** perform the upgrade at the current time.

Following release of a new version of liveCache 7.7 for SCM 5.1, we will release an equivalent or higher version for SCM 7.0 EHP1 as soon as possible, but delays are possible. Normally, with a new Support Package for SCM 7.0 EHP1 there is also a new liveCache version available. For information about planned Support Packages for SCM 7.0 EHP1, see the following:

► <http://service.sap.com/sp-stacks> → SP Stack Information → SP Stack Schedule → SAP EHP1 for SAP SCM 7.0 ◀

**This page is left blank for documents
that are printed on both sides.**

3 Preparation

You complete the upgrade preparations [\[page 11\]](#).

3.1 Completing the Upgrade Preparations

Procedure

SCM Extract / Load Upgrade



NOTE

The report /SAPAPO/OM_LC_UPGRADE_70 issues a message when it is time to upgrade liveCache.

1. Make sure that, during the REQ_APOUPG phase of the SCM upgrade, the SAP liveCache transaction data is downloaded to the SCM database.



NOTE

You **cannot** start the upgrade without a successful download. You do **not** need to copy the master data to the SCM database, because master data – unlike transaction data – is already present in the SCM database (this is true for the SCM system at all times).

2. Make sure that you stop SAP liveCache in the REQ_APOUPG phase.
3. If an SCM instance or another SAP MaxDB instance is running on the SAP liveCache server, stop it.
4. Stop the server for Remote SQL using the command:
`x_server stop.`
5. Stop all DBMGUIs and all DBMCLI sessions.

Inplace Upgrade

1. Stop SAP liveCache with transaction LC10.
2. If an SCM instance or another SAP MaxDB instance is running on the SAP liveCache server, stop it.
3. Stop the server for Remote SQL using the command:
`x_server stop.`
4. Stop all DBMGUIs and all DBMCLI sessions.

**This page is left blank for documents
that are printed on both sides.**

4 Upgrading liveCache

Procedure

1. Log on as a user with administrator rights.
2. Start the upgrade tool with the liveCache DVD or with the downloaded software from the Software Distribution Center (SWDC):

- liveCache DVD

1. Load the liveCache DVD.
2. Change to the DVD:

```
<DVD>: \
```



NOTE

Start the upgrade tool from the **command prompt**. If you start it using the Explorer, error messages are not always displayed.

3. Start the upgrade tool as follows from the command prompt:

```
LCUPDATE.BAT -d <liveCache name> -u <DBM,DBM password> [ -dir <temporary directory>]
```



NOTE

The default temporary directory is C:\temp. If you want to change this setting, use the `-dir` parameter.

- SWDC



NOTE

- Only use this method for start release SCM 5.1 where the liveCache version on DVD is too low. For more information, see *Identifying the Correct Source of the New liveCache Software* [page 8].
- Start the upgrade tool from the **command prompt**. If you start it using the Explorer, error messages are not always displayed.

Start the upgrade tool from the downloaded and extracted file as follows:

SDBUPD

3. Select the SAP liveCache name and enter the DBM user, and DBM password (that is, for the control user).

**This page is left blank for documents
that are printed on both sides.**

5 Post-Upgrade

You perform the following post-upgrade steps:

1. You *perform post-upgrade activities* [[page 15](#)].
2. You *set up a liveCache user* [[page 17](#)].
3. You *install or upgrade Database Studio* [[page 17](#)].

5.1 Performing Post-Upgrade Activities

Procedure

1. Check the setting of OMS_HEAP_LIMIT as described in [SAP Note 833216](#).



CAUTION

It is essential that the SAP liveCache parameter OMS_HEAP_LIMIT is set to a value greater than zero. The unit for this parameter is KB. If you have to change this parameter, restart the SAP liveCache instance so that the change takes effect.

2. Check the instructions in [SAP Note 833216](#) to parameterize the SAP liveCache Release 7.7 server initially if your SAP liveCache start release was 7.2.5.
3. Check the following prerequisites before you upgrade the SAP central or dialog instance:
 - If the liveCache instance is on the same host as the SCM instance, you do not need to update the client software.
 - For the client software upgrade for liveCache, you need to stop the central and dialog instance.
 - If other SAP MaxDB instances are running on the central or dialog instance server, stop them.
 - If other SAP MaxDB instances are running on the central or dialog instance server, stop the server for Remote SQL using the following command:
x_server stop
 - Stop all DBMGUI, SQL Studio, and DBMCLI sessions.
4. Upgrade the database client software for the host where the SAP central and dialog instances are running, depending on whether your client is running on UNIX or Windows:



NOTE

You do **not** need to update the client software if:

- The database instance is on the same host as the SAP instance
- Your client software is already release 7.7 or higher – but in this case we recommend you to always use the latest client software

5.1 Performing Post-Upgrade Activities

Your Client is Running on UNIX

1. Log on as the root user.
2. Stop the SAP central or dialog instances.
3. Start the client software upgrade with the liveCache DVD or with the downloaded software from the Software Distribution Center (SWDC):

- liveCache DVD
`<liveCache DVD>/LCUPDATE.SH -client`
- SWDC

**NOTE**

Only use this method for start release SCM 5.1 where the liveCache version on DVD is too low. For more information, see *Identifying the Correct Source of the New liveCache Software* [page 8].

SDBINST -profile "Runtime For SAP AS"

4. Log on as the <sapsid>adm user.

**CAUTION**

Make sure that you log on from the beginning, because the environment of <sapsid>adm has been changed.

5. Restart the SAP instance:

startsap r3

6. If you stopped other SAP MaxDB instances, restart them.

Your Client is Running on Windows

1. Log on as a user with administrator rights.
2. Stop the SAP central and dialog instances.
3. Stop the server for Remote SQL:

x_server stop

4. Start the client software upgrade with the liveCache DVD or with the downloaded software from the Software Distribution Center (SWDC):

- liveCache DVD
`<liveCache DVD>:\LCUPDATE.BAT -client`
- SWDC

**NOTE**

Only use this method for start release SCM 5.1 where the liveCache version on DVD is too low. For more information, see *Identifying the Correct Source of the New liveCache Software* [page 8].

SDBINST -profile "Runtime For SAP AS"

5. Log on again as a user with administrator rights.

5.2 Setting Up a liveCache Super User

**NOTE**

Make sure that you log on from the beginning because the user environment has been changed.

6. Restart the SAP instance service `SAP<SID>_<instance number>`.
 7. Start the SAP instance using the Microsoft Management Console.
 8. If you stopped other SAP MaxDB instances, restart them and also restart the server for Remote SQL using the following command:
 - `x_server start`
5. If you are performing an upgrade with the SCM extract/load *upgrade strategy* [page 7], follow the SCM upgrade documentation and section C of report /SAPAPO/OM_LC_UPGRADE_70. There you can find descriptions of when to restart liveCache and when to perform a complete liveCache backup.
 6. If you are performing an upgrade with the Inplace *upgrade strategy* [page 7]:
 1. Start the server for Remote SQL using the command `x_server start`.
 2. If you need to import a new SAP liveCache version as part of the SAP liveCache upgrade, do this now.

You can find the newest versions of SAP liveCache at:

► <http://service.sap.com/patches> → A-Z Index → S → SAP SCM → SAP SCM 7.0 → Entry by Component → SAP liveCache → SAP LC/LCAPPS 7.0 → <OS> ◀
 3. Start the SCM and SAP liveCache instances using transaction LC10.
 4. Perform a complete backup of the liveCache data so that you can recover the new liveCache if necessary.

5.2 Setting Up a liveCache Super User

Process

You need to create a liveCache and liveCache applications super user for liveCache administration. Assign the roles `SAP_APO_LC_ALL` or `SAP_LCA_ALL` and `SAP_BC_LVC_SUPERUSER` to the user, as these roles already contain all required privileges.

If you want to create users with limited privileges for transaction LC10 see **SAP Note** [452745](#) for more information about the authorization concept for transaction LC10.

5.3 Installing or Upgrading Database Studio for SAP MaxDB

This section describes how to install or upgrade Database Studio for SAP MaxDB and SAP liveCache on Windows front ends. Database Studio is the database administration tool for SAP MaxDB.

For more information about Database Studio, see one of the following:

- ► http://maxdb.sap.com/doc/7_8/default.htm → Tools → Database Studio ◀

5.3 Installing or Upgrading Database Studio for SAP MaxDB

- <http://www.sdn.sap.com/irj/sdn/maxdb> → SAP MaxDB Knowledge Center → The Complete SAP MaxDB Documentation Set → SAP MaxDB 7.8 Library → Tools → Database Studio ↩

**NOTE**

Database Studio replaces Database Manager GUI and SQL Studio, which were available in previous releases.

The use of Database Studio for SAP liveCache is optional. If you do not want to use it, skip this section.

For up-to-date information about installing Database Studio, see SAP Note [1360996](#).

Prerequisites

- You can install Database Studio on Linux or Windows in your network, even if your database runs on a different operating system. You can then remotely administer the database on a different host. The instructions below refer mainly to the Windows version.

**NOTE**

To run Database Studio on Linux, you need to meet the requirements for the SAP MaxDB database server.

- Your PC must meet the following **minimum** requirements:

- Software requirements:

Operating System Requirements for Database Studio

Operating System	Version
Windows XP	IA32 and X64
Windows 2008	IA64 and X64
Windows 2008 R2	IA64 and X64
Windows Vista	IA32 and X64
Windows 7	IA32 and X64

- Hardware requirements:
 - ◆ RAM: 512 MB (recommended RAM: 1 GB)
 - ◆ Processor speed: 1.5 GHz
 - ◆ Free disk space: 200 MB
 - ◆ Monitor: 1024x768 pixels, 256 colors

- You can obtain the required files from one of the following:

- The DVD for the SAP MaxDB RDBMS or SAP liveCache
- By downloading from:

▶ service.sap.com/patches → Database Patches → MaxDB → MAXDB GUI COMPONENTS/TOOLS → MAXDB DATABASE STUDIO 7.8 ↩

- You need Java version 5 (also known as 1.5) or higher.

To check your Java version, enter the following command:

5.3 Installing or Upgrading Database Studio for SAP MaxDB

java -version

To download Java, go to <http://java.com/en/download>.

- To uninstall the database manager GUI, which is the tool replaced by Database Studio, choose
▶ *Start* → *Settings* → *Control Panel* → *Add/Remove Programs* ◀.

Procedure

1. Start the installation or upgrade as follows (the paths shown are for the 32-bit installation):
 - If you are using the **SAP MaxDB RDBMS DVD**:
`<DVD>:\MAXDB_WINDOWS_I386\SDBSETUP.EXE`
 - If you are using the **SAP liveCache DVD**:
`<DVD>:\LC_WINDOWS_I386\SDBSETUP.EXE`
 - If you are using the downloaded files, simply execute the downloaded SDBSETUP.EXE file. For more information, see SAP Note [1097311](#).

The *Installation Manager* starts.

2. Choose *Start Installation/Upgrade* and then *Custom*.
You see a list of the components to be installed.
3. Deselect all components except *Database Studio*.
4. Choose *Install*.
The installation manager installs Database Studio.
5. If you are prompted to restart your computer after the installation, make sure that you first shut down any databases that are running.

More Information

For more information about Database Studio, including troubleshooting, see SAP Note [1097311](#).

**This page is left blank for documents
that are printed on both sides.**

6 Additional Information

6.1 Operating Information for liveCache

If you manually reinitialize liveCache with transaction LC10, make sure that you **first delete all administration reports**, especially /SAPAPO/DELETE_LC_ANCHORS and SLCA_INIT_FOLLOW_UP, from the definition of the logical liveCache LCA connection.

6.2 Secure Sockets Layer Protocol for Database Server Communication

The SAP MaxDB database server supports the Secure Sockets Layer (SSL) protocol. You can use this protocol to communicate between the database server and its client, here the Application Server (AS). SSL guarantees encrypted data transfer between the SAP MaxDB database server and its client applications. In addition, the server authenticates itself to the client.



CAUTION

There is a performance cost for SSL since the data has to be encrypted, which requires time and processing power.

To use SSL you need to:

1. *Install the SAP cryptographic library* [[page 21](#)] on the client host and on the server host machines
2. *Generate the Personal Security Environment* [[page 23](#)] (PSE) on the server (SSL Server PSE) and on the client (SSL Client PSE).

6.2.1 Installing the SAP Cryptographic Library

The SAP Cryptographic Library supplies the cryptographic functions required to build a database server-client connection using Secure Sockets Layer (SSL) protocol. Therefore, you need to install the SAP Cryptographic Library on the host machine of the SAP MaxDB database server and the SAP Application Server (AS).

The installation package `sapcrypto.car` consists of the following:

- SAP Cryptographic Library: `sapcrypto.d11`
- License ticket: `ticket`
- Configuration tool: `sapgenpse.exe`

You use the configuration tool to generate key pairs and PSEs.

**CAUTION**

The SAP Cryptographic Library is subject to German export regulations and might not be available to some customers. In addition, the library might be subject to the local regulations of your country. These regulations might further restrict import, use, and export or re-export of cryptographic software.

For more information, contact your local SAP representative.

Prerequisites

Download the appropriate SAP Cryptographic Library installation package for your operating system from <http://service.sap.com/swdc>.

Procedure

1. Unpack the installation package for the SAP Cryptographic Library using `sapcar.exe`, which you can find for example on your Installation Master DVD, using the following command:

```
car -xvf SAPCRYPTO.CAR
```

**NOTE**

The remainder of the procedure (as described below) does **not** apply to client applications such as SQL Studio, which do not recognize a “global” directory. In this case, you must copy the SAPCRYPTO installation package to the installation directory of the application. In this directory you need to create a directory `sec`, into which you copy the `ticket` file.

2. Copy the `sapcrypto` library to the `lib` subdirectory of the “global program” directory. You can find the value of the global program directory by entering the following command:

```
sdbconfig IndepPrograms
```

**EXAMPLE**

The global program directory might be called the following:

```
<drive>:\sapdb\programs\lib
```

3. Copy the configuration tool `sapgenpse.exe` to the directory `<global program>\lib`.
4. Create a subdirectory called `sec` under the “global data” directory and copy the `ticket` file into it.

**EXAMPLE**

The result might look as follows:

```
<drive>:\sapdb\data\sec\ticket
```

5. Make sure that only the local system account is allowed to possess access rights to the `sec` directory and the files it contains – including the `ticket` file and the SSL Server PSE – and that access is restricted to `read&write`. Only members of the administrator group can own the files.

Result

The system copies the SAP Cryptographic Library is copied to the application server and configures the environment correctly so that the server can find the library at runtime.

6.2.2 Generating the Personal Security Environment

The information required by the database server or client application to communicate using Secure Sockets Layer are stored in the Personal Security Environment (PSE). The required information differs according to whether SSL PSE is for the server or client:

- SSL Server PSE

This PSE contains the security information from the database server, for example, the public-private cryptographic key pair and certificate chain. To install the SSL Server PSE, you need to generate the PSE. You can either do this for a single database server or system-wide. The SSL Server PSE is called `SDBSSLS.exe`.

- SSL Client PSE

The client requires an anonymous certificate called `SDBSSLA.exe`, which contains the list of the public keys of trustworthy database servers.

Procedure

Generating the SSL Server PSE



NOTE

You need to know the naming convention for the distinguished name of the database server. The syntax of the distinguished name, which you enter in the procedure below, depends on the Certification Authority (CA) that you are using.

1. Change to the `<global programs>\lib` directory.
2. Set up the following environment variable:
`SECUDIR=<global data>\sec`
3. Create a SSL Server PSE, `SDBSSLS.pse`, and generate a certificate request file, `certreq`, in the directory defined by `SECUDIR` (see previous step):

```
sapgenpse gen_pse -v -r <SECUDIR>\certreq -p SDBSSLS.pse "<your distinguished name>"
```

For each database server that uses a server-specific PSE, you must set up a unique certificate request. If you are using a valid system-wide SSL Server PSE, you only need to set up a single certificate request for all servers.

4. Send the certificate request to the CA for signing. You can either send it to the SAP CA or to another CA.

You must make sure that the CA offers a certificate corresponding to the PKCS#7 certificate chain format. Thawte CA at <http://www.thawte.com> offers a suitable certificate, either SSL Chained CA Cert or PKCS#7 certificate chain format.

The CA validates the information contained in the certificate request, according to its own guidelines, and sends a reply containing the public key certificate.

5. After you have received the reply from the CA, make sure that the contents of the certificate request have not been destroyed during download.

For example, if you requested the certificate on a UNIX system and stored it on a Windows front end, the formatting (that is, line indents and line breaks) is affected.

To check the contents, open the certificate request with a text editor (such as Notepad) and repair the line indents and the line breaks.



EXAMPLE

This is an example of a certificate request:

```
-----BEGIN CERTIFICATE REQUEST-----
MIIBPzCBqQIBADAAMIGfMA0GCSqGSIb3DQEBAQUAA4GNADCBiQKBgQD/302IT+/Y
wpignSw7U9FWneyWz3Wi10S18aFCYkRo00wCpD8UwcaC4dds4uGT6h12W1J0/F0tUg
+EQxonZbaRrk9sTa1kn1mqx3YAUe/gEaGdf1wvuYkb0gjMk81iM/jb9BJd8srMPyoBy9jMC7v5u7
+TZWmWa6RjnvC1vYGgMwIDAQABoAAwDQYJKoZIhvcNAQEFBQADgYEAx2zuaTAOKPdGmxUKY1WdasU
pim4vhfaHa7ZDBwipvKJ8akYCT
+dpmVjhcp9E7cUjL80/6Rup5cnLAA05FhVt5MS6zNJa9YYSN9XP+5/
MPF6Q4ayJ0VryTkSpbbPrWLBKh1Dds97LQVUq/myKIAHECwyW6t7sAFJWn4P0fdxmKo= -----END
CERTIFICATE REQUEST-----
```

6. Import the reply to the SSL Server PSE:

1. Copy the text to a temporary file called `srcert`.
2. Enter the following command:

```
sapgenpse import_own_cert -c srcert -p SDBSSLS.pse
```

You have generated the SSL Server PSE. You can now start the XServer as usual (if it is already running, you must stop and restart it).

7. To check whether the SSL functionality is working correctly, view the trace file `ni_server_<local computer name>.trace` in the `<global data>\wrk` directory.

Generating the SSL Client PSE

1. Change to the `<global programs>\lib` directory.
2. Set up the following environment variable:

```
SECUDIR=<global data>\sec
```

3. Create an anonymous client SSL Client PSE, `SDBSSLA.pse` in the directory defined by `SECUDIR` (see previous step):

```
sapgenpse gen_pse -v -noreq -p SDBSSLA.pse
```

You can leave the distinguished name empty.

Before you can establish an SSL connection to a database server, the server certificate must be entered in the PK list of the anonymous client certificate.

4. To see the database server certificate, enter the following command:

```
„x_ping -n <servermode> -c[apture]
```

6.3 Database Directory Structure

You can check whether to trust the database server certificate. The client certificate is not affected by this.

5. Start the import with this command:

```
„x_ping -n <servermode> -i[import]
```

6. To administer the PSE, use the configuration tool `sapgenpse`. For more information, enter the following command:

```
sapgenpse -h
```

**NOTE**

For applications such as SQL Studio replace the global data or global program in the above description with the relevant installation directory.

6.3 Database Directory Structure

As of SAP DB Release 7.2.4, you can set up several database instances with different releases in one user environment. For this the database services are split into the following areas:

- Release-independent programs: `IndependentProgPath`

This area contains all services that are only allowed to exist once per computer and are downward compatible (for example, the server for Remote SQL, `x_server`). Therefore, only programs of the most recent installed version exist here.

You can check the path for `IndependentProgPath` with the following `dbmc1 i` command:

```
dbm_getpath IndepProgPath
```

By default, `IndependentProgPath` is set as follows for the installation:

```
<DB drive>:\sapdb\programs
```

The subdirectory `bin` and, for Windows, the extra directory `pgm` must be specified in the environment variable path.

- Instance data: `IndependentDataPath`

This area contains all data necessary for an instance, including run directories and their parameter files. The directory containing this data is called the `IndependentDataPath`.

You can check the path for `IndependentDataPath` with the following `dbmc1 i` command:

```
dbm_getpath IndepDataPath
```

By default, `IndependentDataPath` is set as follows for the installation:

```
<DB drive>:\sapdb\data
```

The subdirectory `bin` and, for Windows, the extra directory `pgm` must be specified in the environment variable path.

- Instance-dependent programs: `INSTROOT`

This area contains all programs necessary for a running instance. The programs must all correspond to the instance version and are installed once per instance. The programs include, for

6.4 Sample Directory Structure

example, `kernel`, `console`, `dbmsrv`, and so on. The storage location is known as the `INSTROOT` of the instance.

The installation sets up the directory as follows:

```
<DB drive>:\sapdb\<DBNAME>\db
```

You can display instance names and associated `INSTROOT`s on a computer with the following `dbmcli` command:

```
db_enum
```

- Client-runtime libraries and dlls

This area contains shared libraries and dlls required by clients at runtime, including runtime precompilers, ODBC, and so on. The runtime libraries are installed on each computer, but different versions must be possible.

The directories for the runtime software are set up during the installation beneath `IndepProgPath` as follows:

```
<DB_DRIVE>:\<IndepProgPath>\runtime\<version>
```

6.4 Sample Directory Structure

The following graphic shows a sample directory structure:

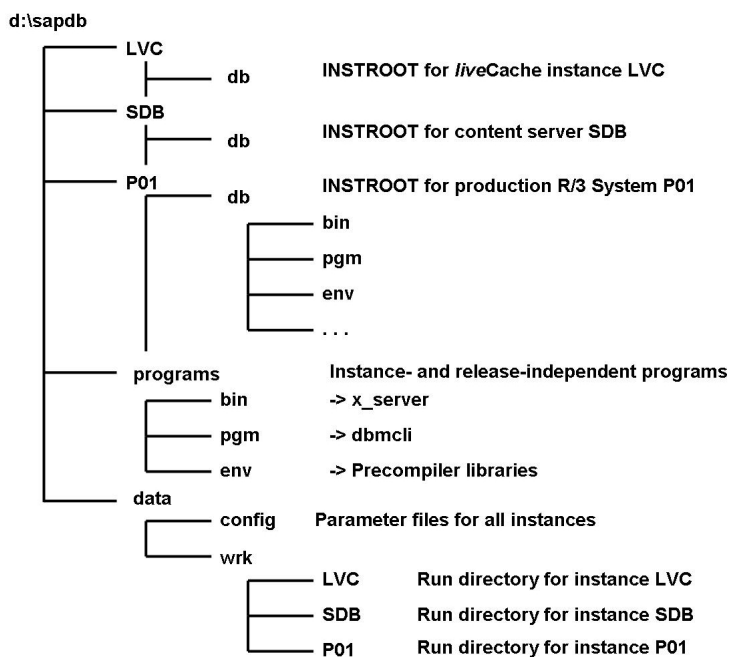

Figure 1:

6.5 Log Files for Troubleshooting

All steps of the upgrade and the associated software installation are logged in the file `SAPliveCacheUpdate_install-<date>-<time>.log` with the following name:

`<i>independent_data_path</i>\wrk\SAPliveCacheUpdate_install-<date>-<time>.log`

If the directory `<i>independent_data_path</i>` is not known at the time of failure, the log is written to the current directory.

Typographic Conventions

Example	Description
<Example>	Angle brackets indicate that you replace these words or characters with appropriate entries to make entries in the system, for example, "Enter your <User Name>".
▶ Example → Example ◀	Arrows separating the parts of a navigation path, for example, menu options
Example	Emphasized words or expressions
Example	Words or characters that you enter in the system exactly as they appear in the documentation
http://www.sap.com	Textual cross-references to an internet address
/example	Quicklinks added to the internet address of a homepage to enable quick access to specific content on the Web
123456	Hyperlink to an SAP Note, for example, SAP Note 123456
Example	<ul style="list-style-type: none"> Words or characters quoted from the screen. These include field labels, screen titles, pushbutton labels, menu names, and menu options. Cross-references to other documentation or published works
Example	<ul style="list-style-type: none"> Output on the screen following a user action, for example, messages Source code or syntax quoted directly from a program File and directory names and their paths, names of variables and parameters, and names of installation, upgrade, and database tools
EXAMPLE	Technical names of system objects. These include report names, program names, transaction codes, database table names, and key concepts of a programming language when they are surrounded by body text, for example, SELECT and INCLUDE
EXAMPLE	Keys on the keyboard

© Copyright 2011 SAP AG. All rights reserved.

No part of this publication may be reproduced or transmitted in any form or for any purpose without the express permission of SAP AG. The information contained herein may be changed without prior notice.

Some software products marketed by SAP AG and its distributors contain proprietary software components of other software vendors.

Microsoft, Windows, Excel, Outlook, and PowerPoint are registered trademarks of Microsoft Corporation.

IBM, DB2, DB2 Universal Database, System i, System i5, System p, System p5, System x, System z, System z10, System z9, z10, z9, iSeries, pSeries, xSeries, zSeries, eServer, z/VM, z/OS, i5/OS, S/390, OS/390, OS/400, AS/400, S/390 Parallel Enterprise Server, PowerVM, Power Architecture, POWER6+, POWER6, POWER5+, POWER5, POWER, OpenPower, PowerPC, BatchPipes, BladeCenter, System Storage, GPFS, HACMP, RETAIN, DB2 Connect, RACF, Redbooks, OS/2, Parallel Sysplex, MVS/ESA, AIX, Intelligent Miner, WebSphere, Netfinity, Tivoli and Informix are trademarks or registered trademarks of IBM Corporation. Linux is the registered trademark of Linus Torvalds in the U.S. and other countries.

Adobe, the Adobe logo, Acrobat, PostScript, and Reader are either trademarks or registered trademarks of Adobe Systems Incorporated in the United States and/or other countries.

Oracle is a registered trademark of Oracle Corporation.

UNIX, X/Open, OSF/1, and Motif are registered trademarks of the Open Group.

Citrix, ICA, Program Neighborhood, MetaFrame, WinFrame, VideoFrame, and MultiWin are trademarks or registered trademarks of Citrix Systems, Inc.

HTML, XML, XHTML and W3C are trademarks or registered trademarks of W3C®, World Wide Web Consortium, Massachusetts Institute of Technology.

Java is a registered trademark of Sun Microsystems, Inc.

JavaScript is a registered trademark of Sun Microsystems, Inc., used under license for technology invented and implemented by Netscape.

SAP, R/3, SAP NetWeaver, Duet, PartnerEdge, ByDesign, SAP BusinessObjects Explorer, and other SAP products and services mentioned herein as well as their respective logos are trademarks or registered trademarks of SAP AG in Germany and other countries.

Business Objects and the Business Objects logo, BusinessObjects, Crystal Reports, Crystal Decisions, WebIntelligence, Xcelsius, and other Business Objects products and services mentioned herein as well as their respective logos are trademarks or registered trademarks of Business Objects Software Ltd. in the United States and in other countries.

Sybase and Adaptive Server, iAnywhere, Sybase 365, SQL Anywhere, and other Sybase products and services mentioned herein as well as their respective logos are trademarks or registered trademarks of Sybase, Inc. Sybase is an SAP company.

All other product and service names mentioned are the trademarks of their respective companies. Data contained in this document serves informational purposes only. National product specifications may vary.

These materials are subject to change without notice. These materials are provided by SAP AG and its affiliated companies ("SAP Group") for informational purposes only, without representation or warranty of any kind, and SAP Group shall not be liable for errors or omissions with respect to the materials. The only warranties for SAP Group products and services are those that are set forth in the express warranty statements accompanying such products and services, if any. Nothing herein should be construed as constituting an additional warranty.

Disclaimer

Some components of this product are based on Java™. Any code change in these components may cause unpredictable and severe malfunctions and is therefore expressly prohibited, as is any decompilation of these components.

Any Java™ Source Code delivered with this product is only to be used by SAP's Support Services and may not be modified or altered in any way.

Documentation in the SAP Service Marketplace

You can find this document at the following address: <http://service.sap.com/instguides>

SAP AG
Dietmar-Hopp-Allee 16
69190 Walldorf
Germany
T +49/18 05/34 34 34
F +49/18 05/34 34 20
www.sap.com