



**SAP SuccessFactors** 

Implementation Guide | PUBLIC

Document Version: 2H 2023 – 2023-12-04

# Replicating Cost Centers from SAP ERP to Employee Central Using SAP Cloud Integration as the Middleware

# Content

- 1 Introduction to Cost Center Replication. . . . . 4**
- 1.1 Before Starting: Am I reading the right documentation?. . . . . 4
- 1.2 Your Integration Team. . . . . 6
- 1.3 Target Group of This Document. . . . . 6
- 2 System Preparation for Cost Center Replication. . . . . 7**
- 2.1 Checking the Minimum Setup Required for Your Systems. . . . . 7
- 2.2 Configuring Length of Cost Center Fields in Employee Central. . . . . 9
- 2.3 Permissions Required for SAP SuccessFactors API Access. . . . . 10
- 3 Integration Scenario for the Replication of Cost Centers. . . . . 13**
- 4 Middleware Setup. . . . . 15**
- 4.1 Middleware Content for Cost Center Replication. . . . . 16
- 4.2 Prerequisites for Using SAP Cloud Integration. . . . . 16
- 4.3 Configuration of SAP Cloud Integration for Cost Center Replication. . . . . 17
  - Configuring Certificates and Permissions. . . . . 18
  - Configuring Credentials for Communication Between SAP Cloud Integration and Employee Central. . . . . 19
  - How to Find the Endpoint URLs. . . . . 20
  - Copying the Integration Package to Your Workspace. . . . . 22
  - Configuring the Integration Flow for Cost Center Replication. . . . . 23
  - Configuring the Language Table for Cost Center Replication. . . . . 28
  - Enabling the SAP ERP Outbound Connection to the Middleware. . . . . 33
- 4.4 Field Mapping in the Middleware. . . . . 34
- 4.5 Monitoring in SAP Cloud Integration. . . . . 35
- 4.6 Reporting Middleware Issues. . . . . 35
- 5 Configuration of Cost Center Replication in the SAP ERP System. . . . . 37**
- 5.1 Customizing Settings for Cost Center Replication. . . . . 37
- 5.2 Enabling Change Pointers. . . . . 38
- 5.3 Configuration of ALE Distribution. . . . . 39
  - Creating an RFC HTTP Connection. . . . . 39
  - Configuring the Logical Systems and the Distribution Model. . . . . 40
  - Creating a Port for Data Exchange with the Middleware. . . . . 40
  - Creating a Partner Profile. . . . . 41
- 6 Replication of Cost Centers to Employee Central. . . . . 42**
- 6.1 Business Logic of Cost Center Replication. . . . . 42

	Lock Flags Controlling the Posting to Cost Centers. . . . .	43
	Cost Center Key Mapping. . . . .	44
6.2	Use Cases of Cost Center Replication. . . . .	44
6.3	Configuration of the Cost Center Replication Program for Initial Replication. . . . .	45
6.4	Configuring and Running Delta Replication. . . . .	47
6.5	Replicating Translated Cost Center Texts. . . . .	47
6.6	User Exits for Cost Center Replication. . . . .	48
<b>7</b>	<b>You're done! What's Next? . . . . .</b>	<b>49</b>
7.1	Performance Optimization of This Integration. . . . .	49

# 1 Introduction to Cost Center Replication

Find out how to implement the integration of SAP SuccessFactors Employee Central with SAP ERP systems regarding cost center replication.

After executing all steps described in this document you will be able to replicate cost centers from the SAP ERP system to Employee Central.

## ⚠ Caution

When you start a new integration project, this is not the right document for you. You can still replicate cost centers using SAP Cloud Integration if you're already using SAP Cloud Integration as middleware in an SAP SuccessFactors Employee Central integration with SAP ERP and are not planning to distribute cost centers to systems other than SAP SuccessFactors. For more information, refer to SAP Note [3255864](#).

If you set up a new integration and are planning to move from SAP ERP to SAP S/4HANA, we recommend that you use the SAP SuccessFactors Employee Central integration with SAP Master Data Integration to replicate cost centers from the SAP S/4HANA system to Employee Central. For more information, refer to [Scenario: Integrating Cost Center from SAP Master Data Integration to Employee Central](#) in *Integrating SAP SuccessFactors Employee Central with SAP Master Data Integration*.

## Related Information

[System Preparation for Cost Center Replication \[page 7\]](#)

[Integration Scenario for the Replication of Cost Centers \[page 13\]](#)

[Middleware Setup \[page 15\]](#)

[Configuration of Cost Center Replication in the SAP ERP System \[page 37\]](#)

[Replication of Cost Centers to Employee Central \[page 42\]](#)

[You're done! What's Next? \[page 49\]](#)

## 1.1 Before Starting: Am I reading the right documentation?

Before you start looking for information in this document, you need to be sure you're looking in the right place.

This document describes how to set up **integration** between SAP ERP and SAP SuccessFactors Employee Central. It assumes that you have a team of experts in place who know their ways in the systems involved in the integration.

What this document does **not** describe:

- How to set up and use Employee Central. For example:
  - How to configure object types in Employee Central. We tell you which prerequisites object types must fulfill so that they can be replicated between SAP ERP and Employee Central. For example, whether

a length restriction applies to a specific field. For basics such as how to restrict the length of a field, please see the Employee Central documentation.

- Why and how to enable Position Management in Employee Central. We tell you what happens in the integration if Position Management is or is not enabled. For basics such as when and how to enable it, please see the Employee Central documentation.
- How to set up and use the SAP ERP system. For example:
  - How to use the Customizing Implementation Guide (IMG) in your system. We tell you which customizing activities and settings are relevant for integration. For basics such as how to make entries in customizing views or how to implement a Business Add-In, please see the SAP ERP documentation.
  - How to create a variant for a program or schedule it to be run in the background. We tell you which programs you need to execute or schedule. For basics such as how to define variants or background jobs, please see the SAP ERP documentation.
- How to set up and use the middleware. For example:
  - How to find and use the monitoring UI. We tell you what you should pay attention to when monitoring integration flows. For basics such as how to use middleware monitoring in general, please see the middleware documentation.
  - How to upload a certificate. We tell you when a certificate is required. For basics such as how to upload it, please see the middleware documentation.

Read the following information to learn how to set up and use the products or modules involved in the integration.

Product / Module	Where to Find Information
Employee Central	<a href="https://help.sap.com/docs/SAP_SUCCESSFACTORS_EMPLOYEE_CENTRAL">https://help.sap.com/docs/SAP_SUCCESSFACTORS_EMPLOYEE_CENTRAL</a> > <i>Implement</i>
SAP ERP	<p>For platform information: <a href="https://help.sap.com/docs/SAP_NETWEAVER">https://help.sap.com/docs/SAP_NETWEAVER</a> &gt; <i>ABAP Platform</i></p> <p>For information about SAP ERP in general: <a href="https://help.sap.com/docs/SAP_ERP">https://help.sap.com/docs/SAP_ERP</a></p> <p>For specific information about SAP ERP HCM: <a href="https://help.sap.com/docs/ERP_HCM">https://help.sap.com/docs/ERP_HCM</a></p>
Middleware	<a href="https://help.sap.com/docs/CLOUD_INTEGRATION">https://help.sap.com/docs/CLOUD_INTEGRATION</a>

### Note

For information about data purge, refer to the following sections in the SAP SuccessFactors guide *Implementing and Managing Data Protection and Privacy*:

- [Purge of Employee Central Data Replicated to the Enterprise Resource Planning \(ERP\) System](#)
- [Purge of Data Related to Data Replication to Employee Central in the Enterprise Resource Planning \(ERP\) System](#)

## 1.2 Your Integration Team

The implementation and integration process of SAP SuccessFactors Employee Central with SAP ERP is a collaborative effort that leverages the skills of various experts.

You need to pull together a team of experts for your implementation project when integrating SAP SuccessFactors Employee Central with SAP ERP.

The following experts are typically involved in the process:

Expert	What the Expert Does
SAP SuccessFactors consultant	<ul style="list-style-type: none"><li>• Is the main point of contact for the entire implementation and integration process.</li><li>• Ensures that all required system settings for Employee Central are done.</li><li>• Works closely with the SAP ERP team, to ensure successful data replication.</li></ul>
Middleware consultant	Provides support on setting up the middleware.
SAP ERP consultant	<ul style="list-style-type: none"><li>• Is the main point of contact for the configuration of SAP ERP according to the needs of the customer.</li><li>• Works closely with the SAP SuccessFactors consultant to ensure successful data replication.</li></ul>

## 1.3 Target Group of This Document

Take a look at the target groups this document is intended for.

The following groups of people will benefit from reading this document:

- Implementation partners, consultants, and Product Support, for fast support of customers and prospective customers
- Cloud operations
- SAP-certified administrators at customer site

## 2 System Preparation for Cost Center Replication

Learn more about what needs to be in place if you want to replicate cost centers to Employee Central.

### [Checking the Minimum Setup Required for Your Systems \[page 7\]](#)

Check if your systems are ready so that you can set up cost center replication from SAP ERP to Employee Central.

### [Configuring Length of Cost Center Fields in Employee Central \[page 9\]](#)

To prepare for cost center replication, make sure that cost center fields in Employee Central have the right field length.

### [Permissions Required for SAP SuccessFactors API Access \[page 10\]](#)

Data replication between SAP SuccessFactors Employee Central and the SAP ERP system requires administrator and user permissions for SAP SuccessFactors APIs.

### 2.1 Checking the Minimum Setup Required for Your Systems

Check if your systems are ready so that you can set up cost center replication from SAP ERP to Employee Central.

#### Procedure

1. Is Employee Central already set up?

For more information, refer to [Implementing Employee Central Core](#).

2. Is the middleware already set up?

For more information about how to set up SAP Cloud Integration, refer to [SAP Cloud Integration](#).

#### Caution

You are only allowed to configure the content as described in this guide. If you make modifications not described in this guide, SAP will not provide support for the modified content.

The middleware content described in this guide is meant for use in SAP Cloud Integration. You are not allowed to deploy it in an on-premise SAP Process Orchestration system. For more information, see SAP Note [2428801](#).

3. Do you meet the minimum setup for on-premise systems?

Table 1: Required Software Component Versions and Support Packages

For this component...	You need this software component version...
SAP NetWeaver	SAP_BASIS with one of the following versions: <ul style="list-style-type: none"> <li>• 700 with SP27 or a higher SP</li> <li>• 701 with SP12 or a higher SP</li> <li>• 702 with SP08 or a higher SP</li> </ul>
SAP ERP	SAP_APPL 600 SP15 or a higher version/SP
Integration add-on for SAP ERP CO Master Data and SAP SuccessFactors Employee Central	ODTFINCC 600 SP10 or higher

For more information, refer to [SFSF EC INTEGRATION 1210](#) in the Software Download Center. You can access the Software Download Center from [SAP for Me](#) by choosing *Systems and Provisioning*.

4. Are the required SAP Notes installed?

Make sure that you have the up-to-date version of each SAP Note, which you can find in SAP for Me at <https://me.sap.com/home>.

Table 2: Required SAP Notes

SAP Note Number	Title	Description
<a href="#">1043195</a>	<i>Configuration of Web service runtime</i>	Gives instructions on how to set up the technical configuration of the Web service runtime environment and how to check it.
<a href="#">1269130</a>	<i>IDoc XML-HTTP SOAP: Problem with SOAP Class</i>	Gives instructions on how to resolve a SOAP error.
<a href="#">1560878</a>	<i>White list for SOAP Processer &amp; IDoc SOAP</i>	Gives instructions on how to explicitly allow objects to be processed by SOAP processor.
<a href="#">857321</a>	<i>Resending HTTP IDocs Automatically in Status 02</i>	Gives instructions on how to send IDocs automatically without problems.
<a href="#">1567897</a>	<i>EA/728/ SOAP_MSGID_PREFIX_INVALID</i>	Ensures that IDoc SOAP communication still works if Employee Central sends sequencing information in the control record field ARCKEY.



SAP Note Number	Title	Description
2255967 	<i>Example implementation for company code mapping of cost center</i>	Provides the CL_ODTF_EC_MAP_COMP_CODE_EXMP class, which you can use as a sample implementation for the <i>Modify Replication IDoc for Cost Centers</i> (ODTF_CO_REPL_IDOC_COST_CENTERS) Business Add-In (BAI) to replace the SAP ERP company code with the corresponding Employee Central company code when transferring cost centers. Implement this BAI if the COMPANY_CODE_ID field of the IDoc should contain the Employee Central company code instead of the SAP ERP company code.

## 2.2 Configuring Length of Cost Center Fields in Employee Central

To prepare for cost center replication, make sure that cost center fields in Employee Central have the right field length.

### Context

If the maximum length defined for an Employee Central cost center field allows for fewer characters than the corresponding SAP ERP field can have, the replication process stops. Therefore, make sure to define a field length in Employee Central that is at least the same as the length of the corresponding SAP ERP fields provided in the IDoc.

### Procedure

1. Go to the *Develop IDoc Types* (WE30) transaction in your SAP ERP system.
2. Enter the object name **ODTF\_CCTR01**, select the *Basic Type* option, and choose *Display*.
3. Expand the structure and double-click a segment type such as *E101ODTF\_S\_COST\_CENTER\_NAME*.
4. Choose *Segment Editor*.
5. Check the defined field lengths in the *Segment Editor* and configure the field lengths in Employee Central accordingly, as shown in the example.

Table 3: Example: Length of Name and Description Fields

Employee Central Field	Corresponding Field in the IDoc	SAP ERP Data Element Associated to IDoc Field	Recommended Minimum Field Length
name	NAME_SHORT	KTEXT	20 characters
description	NAME	AD_NAME1	40 characters

## 2.3 Permissions Required for SAP SuccessFactors API Access

Data replication between SAP SuccessFactors Employee Central and the SAP ERP system requires administrator and user permissions for SAP SuccessFactors APIs.

The permissions listed here grant users and administrators access to the SAP SuccessFactors OData API and SFAPI. SFAPI access includes access to `CompoundEmployee` API.

For more information about role-based permissions – what they are, how they work, how you set them up – refer to [Implementing Role-Based Permissions](#) in the SAP Help Portal.

Table 4: Permissions Required for API Access

Who's This Permission For?	Permission Location	Permission Name
User	<i>General User Permission</i>	<i>SFAPI User Login</i>
Administrator	<i>Employee Central API</i>	<i>Employee Central Foundation SOAP API</i>

Who's This Permission For?	Permission Location	Permission Name
Administrator	<i>Employee Central API</i>	<i>Employee Central HRIS SOAP API or Employee Central Compound Employee API (restricted access)</i>
		<p><b>i Note</b></p> <p>Either grant the <i>Employee Central HRIS SOAP API</i> permission, to give the administrator unrestricted access to the <code>CompoundEmployee</code> API. Or grant the <i>Employee Central Compound Employee API (restricted access)</i> permission, to restrict the access to the data of specific employees. Don't select both permissions for the same permission role. For more information, refer to <a href="#">Granting Permissions for Full Access to the CompoundEmployee API</a> and <a href="#">Granting Permissions for Restricted Access to the CompoundEmployee API</a> in the <i>Employee Central Compound Employee API</i> guide.</p>
Administrator	<i>Employee Central API</i>	<i>Employee Central Compound Employee API (restricted segment access)</i>
		<p><b>i Note</b></p> <p>With this permission, you can further restrict either the <i>Employee Central HRIS SOAP API permission</i> or the <i>Employee Central Compound Employee API (restricted access)</i> permission. The <i>Employee Central Compound Employee API (restricted segment access)</i> permission allows the user with this role to access <code>CompoundEmployee</code> segments according to the configuration setup only. For more information, refer to <a href="#">Granting Permissions for Segment Access to the CompoundEmployee API</a> in the <i>Employee Central Compound Employee API</i> guide.</p>
Administrator	<i>Employee Central API</i>	<i>Employee Central Foundation OData API (read-only)</i>

Who's This Permission For?	Permission Location	Permission Name
Administrator	<i>Employee Central API</i>	<i>Employee Central HRIS OData API (read-only)</i>
Administrator	<i>Employee Central API</i>	<i>Employee Central Foundation OData API (editable)</i>
Administrator	<i>Employee Central API</i>	<i>Employee Central HRIS OData API (editable)</i>
Administrator	<i>Metadata Framework</i>	<i>Admin access to MDF OData API</i>

### i Note

This permission is required for snapshot pagination. Snapshot pagination is used in all integration flows that perform an OData query. This applies to the following integration flows:

- *Replicate Organizational Objects from SAP SuccessFactors Employee Central to SAP ERP or SAP S4HANA*
- *Replicate Time Off Data from SAP SuccessFactors Employee Central to SAP ERP*
- *Replicate Time Sheet Data from SAP SuccessFactors Employee Central to SAP ERP*

# 3 Integration Scenario for the Replication of Cost Centers

Find out about the systems and the technical objects that are involved in the replication scenario for cost centers and cost center assignments.

## Systems Involved in Cost Center Replication

The SAP ERP (Financials) system is always the leading system for cost centers.

Employee Central is the leading system for the assignment of employees to cost centers or cost distribution lists. The information is passed over through employee master data replication to the SAP ERP (Financials) system.

The replication of employee data depends on the correct distribution of cost centers from the Financials system to Employee Central.

## Technical Objects Used by Cost Center Replication

The replication of cost centers can be either file based, using Comma-Separated Values (CSV) files, or message-based, using Intermediate Documents (IDocs).

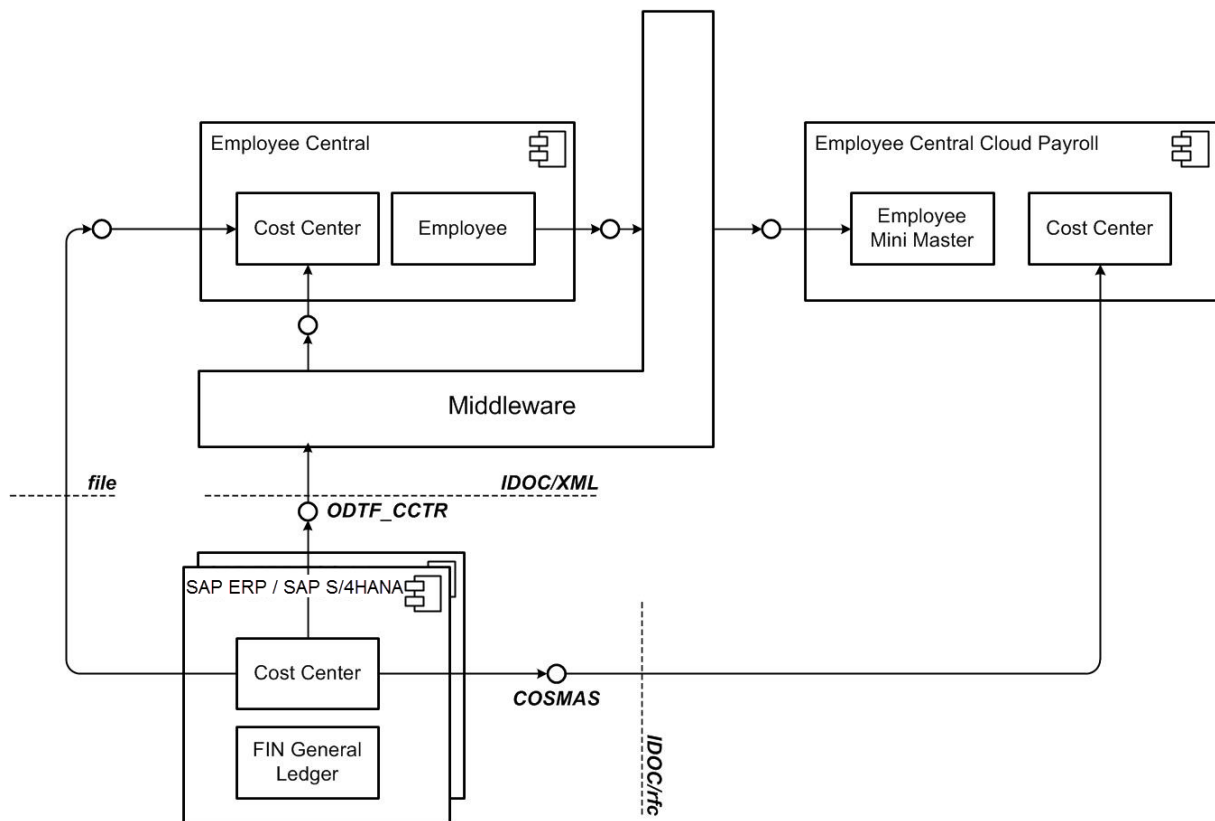

Figure 1: Technical Overview

The file-based option is useful for a quick system setup in the beginning of the project. It can also be used to regularly update Employee Central with delta changes. For details, please see the documentation of the `ODTF_REPL_CC_CSV` program in your SAP ERP system. This program allows downloading files directly to your front-end PC as well as storing them on a server for automated distribution.

The message-based replication is useful for making regular updates. It uses the `ODTF_CCTR` IDoc. Employee Central Payroll is supplied with a different IDoc: `COSMAS`.

To enable delta loads for both variants, file-based and message-based, change pointers are used in SAP ERP.

## Related Information

[Enabling Change Pointers \[page 38\]](#)

[Configuring and Running Delta Replication \[page 47\]](#)

# 4 Middleware Setup

Set up SAP Cloud Integration as the middleware, to use it in integration between Employee Central and the SAP ERP system.

## i Note

For more information about which versions of the middleware content provided for this integration are still supported and which have been deprecated, refer to SAP Note [2684991](#).

## ⚠ Caution

You are only allowed to configure the content as described in this guide. If you make modifications not described in this guide, SAP will not provide support for the modified content.

The middleware content described in this guide is meant for use in SAP Cloud Integration. You are not allowed to deploy it in an on-premise SAP Process Orchestration system. For more information, see SAP Note [2428801](#).

### [Middleware Content for Cost Center Replication \[page 16\]](#)

Get an overview of the integration content that's available in SAP Cloud Integration for replicating cost centers from SAP ERP to Employee Central.

### [Prerequisites for Using SAP Cloud Integration \[page 16\]](#)

Before you start configuring SAP Cloud Integration for this scenario, make sure that the prerequisites are fulfilled.

### [Configuration of SAP Cloud Integration for Cost Center Replication \[page 17\]](#)

Some configuration steps are required to set up the integration flow for cost center replication.

### [Field Mapping in the Middleware \[page 34\]](#)

Here's how IDoc nodes and attributes from SAP ERP are mapped to their Employee Central counterparts.

### [Monitoring in SAP Cloud Integration \[page 35\]](#)

Use the monitoring features of SAP Cloud Integration to check whether any issues occurred in your middleware processes.

### [Reporting Middleware Issues \[page 35\]](#)

Report a case if you have issues that you can't solve using the monitoring in SAP Cloud Integration, providing information about the process run.

## 4.1 Middleware Content for Cost Center Replication

Get an overview of the integration content that's available in SAP Cloud Integration for replicating cost centers from SAP ERP to Employee Central.

Replication of cost centers from SAP ERP uses the following integration packages and integration flows:

Integration Package	Contained Integration Flow
<i>SAP ERP or SAP S/4HANA Integration with SAP SuccessFactors Employee Central: Cost Center</i>	<i>Replicate Cost Centers from SAP ERP or SAP S/4HANA to SAP SuccessFactors Employee Central</i>

Here's a graphical overview of how the integration flow works and how the systems interact with each other.

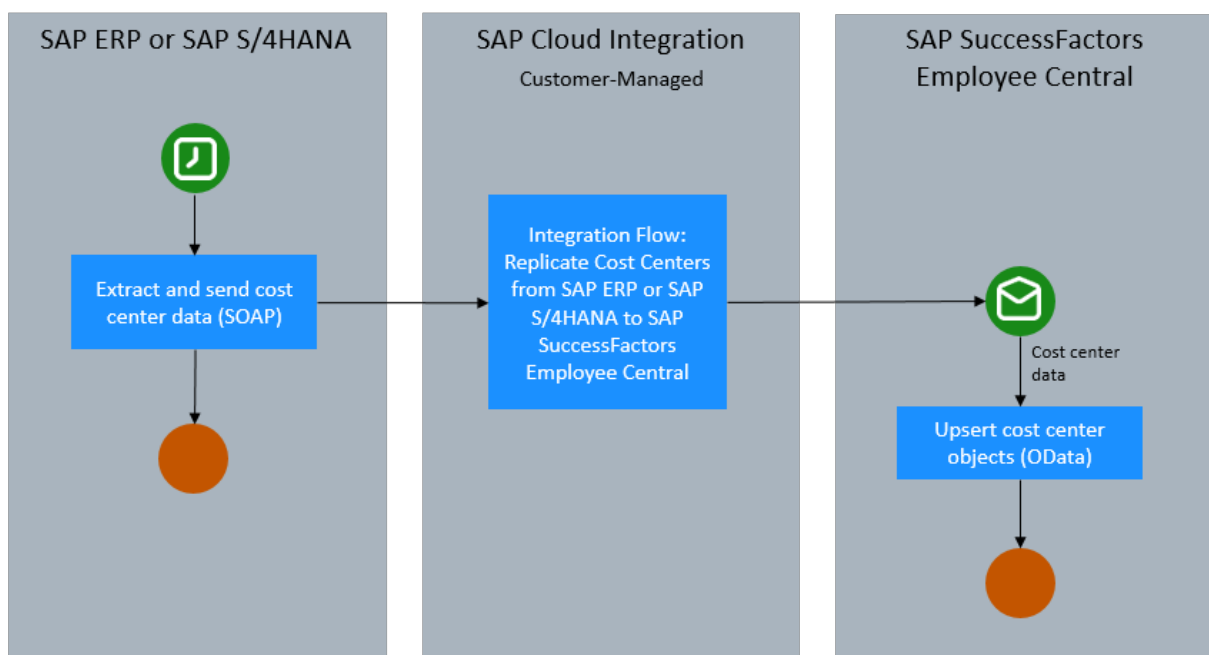

Figure 2: Replication of Cost Centers to Employee Central

## 4.2 Prerequisites for Using SAP Cloud Integration

Before you start configuring SAP Cloud Integration for this scenario, make sure that the prerequisites are fulfilled.

Some basic things need to be in place before you can set up the integration flows in SAP Cloud Integration. For more information, refer to [Initial Setup](#).

- You've been provided with an SAP Cloud Integration account.
- You have access to the SAP Cloud Integration Web UI. For details, refer to [Tool Access](#).
- You have access to the runtime node. For details, refer to [Runtime in Detail](#).
- You have an SAP Cloud Integration communication user, which enables the customer system for authentication based on user credentials. SAP Community Network (SCN) users are used for this purpose.



For details, refer to the SAP Cloud Integration notification email you've received from SAP and to [Creating a User for Cloud Integration, Neo Environment](#).

## 4.3 Configuration of SAP Cloud Integration for Cost Center Replication

Some configuration steps are required to set up the integration flow for cost center replication.

The cost center integration scenario consists of only one integration process. The communication within this scenario is as follows:

1. The SAP ERP system sends cost center data to the middleware.
2. The middleware performs a mapping and sends the result to Employee Central.

Go through the following steps to set up the integration flow.

1. [Configuring Certificates and Permissions \[page 18\]](#)  
Configure certificates and permissions to enable a secure connection between your SAP ERP system and SAP Cloud Integration.
2. [Configuring Credentials for Communication Between SAP Cloud Integration and Employee Central \[page 19\]](#)  
Create and deploy the credentials for the technical integration user. SAP Cloud Integration needs the credentials for communication with SAP SuccessFactors Employee Central.
3. [How to Find the Endpoint URLs \[page 20\]](#)  
Find the URLs you need to enter so that senders and receivers of the integration flows know which system they are to address.
4. [Copying the Integration Package to Your Workspace \[page 22\]](#)  
Copy and deploy the integration content provided for cost center replication from SAP ERP to Employee Central.
5. [Configuring the Integration Flow for Cost Center Replication \[page 23\]](#)  
Configure the sender, the receiver, and the process parameters of the integration flow we provide for replication of cost centers to Employee Central.
6. [Configuring the Language Table for Cost Center Replication \[page 28\]](#)  
If you want to replicate translated descriptions and names of cost centers, map the languages that you use in SAP ERP and Employee Central.
7. [Enabling the SAP ERP Outbound Connection to the Middleware \[page 33\]](#)  
Activate the SAP ERP outbound web services used by this integration to set up the connections for communication from the SAP ERP system to SAP Cloud Integration.

## 4.3.1 Configuring Certificates and Permissions

Configure certificates and permissions to enable a secure connection between your SAP ERP system and SAP Cloud Integration.

### Context

Even if you use basic authentication for your integration, certificates are needed to enable a secure HTTPS communication between SAP ERP and SAP Cloud Integration. For more information, refer to [Connecting a Customer System to Cloud Integration](#). The SAP Cloud Integration user must also have the required permissions.

### Procedure

1. Add the root certificate from SAP Cloud Integration in the [Trust Manager](#) (STRUST) transaction in your SAP ERP system, for connections initiated by the SAP ERP system to SAP Cloud Integration.

For more information, refer to [Trust Manager](#).

2. Add the root certificate from SAP ERP in the [Keystore](#) in your SAP Cloud Integration tenant, for connections initiated by SAP Cloud Integration to the SAP ERP system.

For more information, refer to:

- [Trust Manager](#) and [Exporting the AS ABAP's Public-Key Certificate](#) for the SAP ERP system
- [Importing a Certificate](#) for SAP Cloud Integration

3. Make sure that the SAP Cloud Integration user that is used to trigger calls from outside the middleware to SAP Cloud Integration has the necessary permission for sending messages.

For more information, refer to [Persona](#) for the Cloud Foundry Environment or [Persona](#) for the Neo Environment.

**Task overview:** [Configuration of SAP Cloud Integration for Cost Center Replication \[page 17\]](#)

**Next task:** [Configuring Credentials for Communication Between SAP Cloud Integration and Employee Central \[page 19\]](#)

## 4.3.2 Configuring Credentials for Communication Between SAP Cloud Integration and Employee Central

Create and deploy the credentials for the technical integration user. SAP Cloud Integration needs the credentials for communication with SAP SuccessFactors Employee Central.

### Prerequisites

Determine the SAP SuccessFactors credentials for the API user you want to use for the integration. The user must have the permission to call SAP SuccessFactors OData APIs.

### Context

For more information about credentials artifacts and other security material in SAP Cloud Integration, refer to [Managing Security Material](#).

### Procedure

1. Go to the SAP Cloud Integration Web UI and choose [Operations View](#) from the top-level menu on the left.
2. Choose [Manage Security](#) > [Security Material](#).
3. To create a credentials artifact for the communication between SAP Cloud Integration and Employee Central, choose [Create](#) and select a credentials type.
  - If you want to use the [Basic](#) authentication type for Employee Central receivers, select [User Credentials](#) and deploy two credentials artifacts with the following attributes:

Table 5: Credentials Artifact with Type [SuccessFactors](#)

Field Name	User Action and Values
Name	Enter any name.
Type	Select <a href="#">SuccessFactors</a> .
User	Enter the name of the SAP SuccessFactors API user.
Password	Enter the password of the SAP SuccessFactors API user.
Company ID	Enter the name of your SAP SuccessFactors Employee Central instance.

- If you want to use the [OAuth2 SAML Bearer Assertion](#) authentication type for Employee Central receivers, select [OAuth2 SAML Bearer Assertion](#) and deploy a corresponding credentials artifact. For more information, refer to [Deploying an OAuth2 SAML Bearer Assertion](#).

## Next Steps

You enter the name given to these credentials artifacts when you configure the integration flow.

**Task overview:** [Configuration of SAP Cloud Integration for Cost Center Replication \[page 17\]](#)

**Previous task:** [Configuring Certificates and Permissions \[page 18\]](#)

**Next:** [How to Find the Endpoint URLs \[page 20\]](#)

## Related Information

[Permissions Required for SAP SuccessFactors API Access \[page 10\]](#)

### 4.3.3 How to Find the Endpoint URLs

Find the URLs you need to enter so that senders and receivers of the integration flows know which system they are to address.

[Finding the URL for Communication from SAP ERP to the Middleware \[page 21\]](#)

Determine the endpoint URL for the middleware that you need to enter in SAP ERP.

[Finding the URL for Communication from the Middleware to Employee Central \[page 22\]](#)

Determine the endpoint URL for Employee Central that you need to enter in the middleware.

**Parent topic:** [Configuration of SAP Cloud Integration for Cost Center Replication \[page 17\]](#)

**Previous task:** [Configuring Credentials for Communication Between SAP Cloud Integration and Employee Central \[page 19\]](#)

**Next task:** [Copying the Integration Package to Your Workspace \[page 22\]](#)

### 4.3.3.1 Finding the URL for Communication from SAP ERP to the Middleware

Determine the endpoint URL for the middleware that you need to enter in SAP ERP.

#### Context

Since the integration flow for cost center replication is triggered by the SAP ERP system, SAP ERP needs to know the endpoint URL it is to call in the middleware.

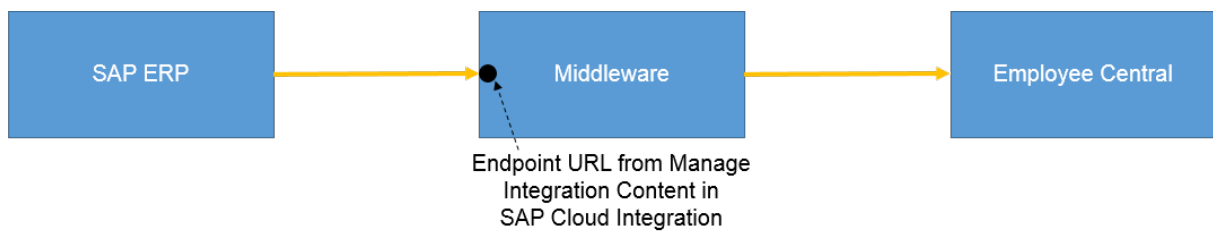

Figure 3: Endpoint URL in the Middleware

#### Procedure

1. Go to [Manage Integration Content](#) in SAP Cloud Integration.
2. Copy the URL shown in the [Endpoints](#) section.

For more information, refer to [Managing Integration Content](#).

The URL looks like this: `https://<runtime URL of your SAP Cloud Integration environment>/cxf/<sender address>`

#### Note

The sender address part is the suffix you enter in the [Address](#) field of the sender when setting up the corresponding integration flow. To get the complete endpoint URL, configure and deploy the integration flow first, then copy the URL from [Manage Integration Content](#).

## 4.3.3.2 Finding the URL for Communication from the Middleware to Employee Central

Determine the endpoint URL for Employee Central that you need to enter in the middleware.

### Context

To be able to trigger calls to Employee Central, the middleware needs to know the OData API endpoint URL it is to call there.



Figure 4: Endpoint URL in Employee Central

### Procedure

1. Check which is your data center.
2. When setting up the integration flow, choose *Select* next to the *Address* field to add the base URL of your SAP SuccessFactors system, depending on your data center.

Here are some examples of what the URL might look like:

- `https://api10.successfactors.com`
- `https://api15.sapsf.cn`
- `https://api2.successfactors.eu`

## 4.3.4 Copying the Integration Package to Your Workspace

Copy and deploy the integration content provided for cost center replication from SAP ERP to Employee Central.

### Context

You use the SAP Cloud Integration Web UI to access and manage integrations configured in SAP Cloud Integration, such as cost center replication. For more information, refer to [Developing Integration Content With SAP Cloud Integration](#).

## Procedure

1. Go to the SAP Cloud Integration tenant for which you want to set up the integration content.
2. Browse the content catalog to find the *SAP ERP or SAP S/4HANA Integration with SAP SuccessFactors Employee Central: Cost Center* integration package.
3. Copy the content of the integration package to your workspace to be able to configure and deploy it.

## Next Steps

Configure the integration flow.

**Task overview:** [Configuration of SAP Cloud Integration for Cost Center Replication \[page 17\]](#)

**Previous:** [How to Find the Endpoint URLs \[page 20\]](#)

**Next task:** [Configuring the Integration Flow for Cost Center Replication \[page 23\]](#)

## 4.3.5 Configuring the Integration Flow for Cost Center Replication

Configure the sender, the receiver, and the process parameters of the integration flow we provide for replication of cost centers to Employee Central.

## Context

You make the following settings for the *Replicate Cost Centers from SAP ERP or SAP S4HANA to SAP SuccessFactors Employee Central* integration flow.

## Procedure

1. Configure the *SAP\_ERP* sender on the first tab.

Table 6: Sender Configuration

Field	What to Enter
<i>Sender</i>	Choose <i>SAP_ERP</i> .

Field	What to Enter
<i>Adapter Type</i>	Choose <i>IDOC</i> .  For more information, refer to <a href="#">IDoc Adapter</a> .
<i>Address</i>	The default entry is / <b>ERP_to_EC_CostCenter_Replication_IDoc</b> . You can change the default. The suffix you enter here is added to the service endpoint URL. It must be unique for each process instance. It's used to uniquely address this specific process instance.
<i>Authorization</i>	Choose <i>User Role</i> .
<i>User Role</i>	Select the role that you've configured.  For more information, refer to <a href="#">Connection Setup for Inbound Communication - Integration Flow Endpoints</a> .

2. Configure the *SFSF\_EC* receiver on the second tab.

Table 7: Receiver Configuration

Field	What to Enter
<i>Receiver</i>	Choose <i>SFSF_EC</i> .
<i>Adapter Type</i>	Choose <i>SuccessFactors</i> .  For more information, refer to <a href="#">SuccessFactors (OData V2) Adapter</a> .
<i>Address</i>	Choose <i>Select</i> to add the base URL of your SAP SuccessFactors system, depending on your data center.  <div style="border-left: 2px solid orange; padding-left: 10px; background-color: #f0f0f0;"> <p><b>! Restriction</b></p> <p>We don't support IP addresses in URLs as part of our reference architecture. Use domain names instead. If you think you have a special case that requires IP addresses instead of domain names, contact Product Support.</p> </div>
<i>Authentication</i>	Choose either <i>Basic</i> or <i>OAuth2 SAML Bearer Assertion</i> .



Field	What to Enter
<i>Credential Name</i>	<p>If you've selected <i>Basic</i> for <i>Authentication</i>: Enter the name of the credentials artifact with the type <i>SuccessFactors</i> that you created before.</p> <p>If you've selected <i>OAuth2 SAML Bearer Assertion</i> for <i>Authentication</i>: Enter the name of the credentials artifact with the type <i>OAuth2 SAML Bearer Assertion</i> that you created before.</p>
<i>Timeout (in min)</i>	Use the default value. Only change this value if you're facing issues. In that case, try a higher number.

3. Configure the process parameters on the last tab.

Table 8: Process Parameters

Field	What to Enter
<i>ADD_INACTIVE_REC_IF_DELIMITED</i>	<p>This parameter is optional. The default is <b>false</b>. Enter <b>true</b> to indicate that an inactive record, which is valid until system high date, is to be added in Employee Central if the cost center is delimited in SAP ERP. In Employee Central, the last data record of a cost center must have unlimited validity. That's why, if you enter <b>false</b>, the last delimited record that's replicated from SAP ERP is extended in Employee Central.</p>
<i>COMPANY_ID_TARGET_FIELD</i>	<p>This parameter is optional. Enter either the field that represents the legal entity in your SAP SuccessFactors instance. Or else, specify the name of the custom field in SAP SuccessFactors that is to contain the company ID. This ID is transferred from the <i>Company Code</i> (<i>COMPANY_CODE_ID</i>) field of the IDoc.</p> <p>To replace the SAP ERP company code with the Employee Central company code in the IDoc, implement the <i>Modify Replication IDoc for Cost Centers</i> (<i>ODTF_CO_REPL_IDOC_COST_CENTERS</i>) Business Add-In (BAI) in the SAP ERP system. You can use the sample implementation class <i>CL_ODTF_EC_MAP_COMP_CODE_EXMPL</i> as an example for your BAI implementation.</p> <p>If you leave this parameter blank, no mapping of values from the SAP ERP field <i>COMPANY_CODE_ID</i> to Employee Central company codes takes place. If you define a mapping, however, make sure that a value is actually transferred. Otherwise, if the parameter remains empty, the process stops.</p>

## Field

## What to Enter

[ENABLE\\_PAYLOAD\\_LOGGING](#)

Enter **true** to transfer extended information to the process log in the middleware to be able to analyze issues more easily. You can also reset the parameter to **false** again if you no longer need the extended log.

### ⚠ Caution

For data protection reasons, enable the extended log for troubleshooting purposes only. Make sure that you disable the parameter again afterwards.

If you enable the extended log, the complete message payload containing all data that is to be transferred is stored in the log. Make sure that you configure permissions in a way that only authorized persons can view the payload in the log. Also ensure that you're compliant with the data protection and privacy regulations so that your data gets the highest level of protection.

For more information, refer to:

- [Data Protection and Privacy](#)
- [Identity and Access Management](#) and [Persona](#) for the Cloud Foundry Environment
- [Managing Users and Role Assignments](#) and [Persona](#) for the Neo Environment

[ERP\\_DEFAULT\\_LANGUAGE](#)

This parameter is mandatory. Enter an SAP ERP language code (such as **E** for English). This defines the default language to be used when cost center texts are transferred from SAP ERP to Employee Central.

### i Note

You don't need to map the default language using the [Map Cost Center Language Keys from SAP ERP or SAP S/4HANA to Language Keys from SAP SuccessFactors Employee Central](#) value mapping (as shown in the next step).

Field	What to Enter
<p><i>PERSON_RESP_TARGET_FIELD</i></p>	<p>This parameter is optional. Enter either the <i>costCenterManager</i> field. Or else, specify the name of the custom field in Employee Central that is to contain the person responsible for the cost center. This information is transferred from the <i>Person Responsible</i> (ASS_MGR_EE_TEXT) field of the IDoc.</p> <div data-bbox="826 577 1401 763" style="border: 1px solid #ccc; padding: 5px;"> <p><b>i Note</b></p> <p>The <i>costCenterManager</i> field is of type <i>User ID</i>. If you specify this field, ensure that a user ID is transferred that is valid in SAP SuccessFactors Employee Central.</p> </div> <p>Leave the parameter blank if you don't need to transfer the cost center's responsible person.</p>
<p><i>USE_EXTERNAL_COST_CENTER</i></p>	<p>Enter <b>true</b> to replicate the cost center ID from the REMOTE_EXTERNAL_OBJECT_ID IDoc field in SAP ERP to the <i>External Object ID</i> (costcenterExternalObjectID) field of the cost center in Employee Central – in addition to the cost center ID from the REMOTE_OBJECT_ID IDoc field in SAP ERP, which is always replicated to the <i>Code</i> (external-Code) field of the cost center in Employee Central.</p> <div data-bbox="826 1137 1401 1700" style="border: 1px solid #ccc; padding: 5px;"> <p><b>i Note</b></p> <p>If you set this parameter to <b>true</b>, ensure that the visibility of the <i>External Object ID</i> field of the <i>Cost Center</i> object definition in Employee Central is <i>Editable</i>.</p> <p>If you set this parameter to <b>true</b> to fill the <i>External Object ID</i> field in cost center replication to Employee Central, also use the key from this field when replicating cost center assignments <b>from</b> Employee Central to the SAP ERP system. If you set this parameter to <b>false</b>, the <i>External Object ID</i> field isn't filled. That's why in this case you need to use the key from the <i>Code</i> field of the cost center in Employee Central when replicating cost center assignments to SAP ERP.</p> </div>

## Next Steps

Next, configure the language table if you want to replicate translated descriptions and names of cost centers.

**Task overview:** [Configuration of SAP Cloud Integration for Cost Center Replication \[page 17\]](#)

**Previous task:** [Copying the Integration Package to Your Workspace \[page 22\]](#)

**Next task:** [Configuring the Language Table for Cost Center Replication \[page 28\]](#)

## 4.3.6 Configuring the Language Table for Cost Center Replication

If you want to replicate translated descriptions and names of cost centers, map the languages that you use in SAP ERP and Employee Central.

### Prerequisites

You've configured the integration flow for cost center replication.

You can deploy the integration flow several times, but the value mapping only once. If you create multiple instances of the integration flow, they must use the same value mapping.

You can only map a language if the corresponding language pack was enabled in Provisioning for Employee Central.

#### → Remember

As a customer, you don't have access to Provisioning. To complete tasks in Provisioning, contact your implementation partner or Account Executive. For any non-implementation tasks, contact Product Support.

### Context

You can use the following SAP ERP languages:

Table 9: SAP ERP Languages

Language Key	ISO Language Key	Language
0	SR	Serbian
1	ZH	Chinese
2	TH	Thai
3	KO	Korean

Language Key	ISO Language Key	Language
4	RO	Romanian
5	SL	Slovenian
6	HR	Croatian
7	MS	Malay
8	UK	Ukrainian
9	ET	Estonian
A	AR	Arabic
B	HE	Hebrew
C	CS	Czech
D	DE	German
E	EN	English
F	FR	French
G	EL	Greek
H	HU	Hungarian
I	IT	Italian
J	JA	Japanese
K	DA	Danish
L	PL	Polish
M	ZF	Chinese trad.
N	NL	Dutch
O	NO	Norwegian
P	PT	Portuguese
Q	SK	Slovak
R	RU	Russian
S	ES	Spanish
T	TR	Turkish

Language Key	ISO Language Key	Language
U	FI	Finnish
V	SV	Swedish
W	BG	Bulgarian
X	LT	Lithuanian
Y	LV	Latvian
Z	Z1	Customer reserve
a	AF	Afrikaans
b	IS	Icelandic
c	CA	Catalan
d	SH	Serbian (Latin)
i	ID	Indonesian
#	HI	Hindi
#	KK	Kazakh
#	VI	Vietnamese

You can use the following Employee Central languages:

Table 10: Employee Central Languages

Language	Locale
Indonesian	bs_ID
Malay	bs_BS
Czech	cs_CZ
Welsh	cy_GB
Danish	da_DK
German	de_DE
English UK	en_GB
English US	en_US
Spanish (Mexico)	es_MX

Language	Locale
Spanish (Spain)	es_ES
French)	fr_FR
Canadian French	fr_CA
Croatian	hr_HR
Italian	it_IT
Hungarian	hu_HU
Dutch)	nl_NL
Norwegian	nb_NO
Polish	pl_PL
Portuguese	pt_PT
Brazilian Portuguese	pt_BR
Romanian	ro_RO
Swiss High German	de_CH
Slovak	sk_SK
Slovenian	sl_SI
Serbian	sr_RS
Finnish	fi_FI
Swedish	sv_SE
Vietnamese	vi_VN
Turkish	tr_TR
Greek	el_GR
Bulgarian	bg_BG
Russian	ru_RU
Ukrainian	uk_UA
Hebrew	iw_IL
Arabic	ar_SA

Language	Locale
Hindi	hi_IN
Thai	th_TH
Korean	ko_KR
Japanese	ja_JP
Simplified Chinese	zh_CN
Traditional Chinese	zh_TW

The *Map Cost Center Language Keys from SAP ERP or SAP S/4HANA to Language Keys from SAP SuccessFactors Employee Central* value mapping shows some example mappings. You can't use these example mappings in the productive mode. If you want to replicate translated texts for cost centers, always configure mappings for all languages you need. If no mapping is configured for a language, no translated texts are replicated for this language.

## Procedure

1. Select the *Map Cost Center Language Keys from SAP ERP or SAP S/4HANA to Language Keys from SAP SuccessFactors Employee Central* value mapping.
2. Enter the language key from SAP ERP and the locale from Employee Central.

### ❖ Example

Enter the following keys.

Table 11: Example: Map SAP ERP Language Keys to Employee Central Locales

SAP ERP Language	Employee Central Locale
<b>D</b>	<b>de_DE</b>
<b>E</b>	<b>en_US , en_GB</b>

In the example, the SAP ERP language key E for English is mapped to two Employee Central locales for English. This means that the integration flow replicates the English cost center texts from the SAP ERP system to both localized Employee Central versions (en\_US and en\_GB).

3. Repeat the previous step for all languages you want to map.



## Next Steps

Select the *Replicate all languages (only supported for replication to Employee Central)* checkbox on the selection screen of the `ODTF_REPL_CC` program when you run data extraction in the SAP ERP system.

**Task overview:** [Configuration of SAP Cloud Integration for Cost Center Replication \[page 17\]](#)

**Previous task:** [Configuring the Integration Flow for Cost Center Replication \[page 23\]](#)

**Next task:** [Enabling the SAP ERP Outbound Connection to the Middleware \[page 33\]](#)

## Related Information

[Configuration of the Cost Center Replication Program for Initial Replication \[page 45\]](#)

## 4.3.7 Enabling the SAP ERP Outbound Connection to the Middleware

Activate the SAP ERP outbound web services used by this integration to set up the connections for communication from the SAP ERP system to SAP Cloud Integration.

### Context

The replication of cost centers uses Application Link Enabling (ALE) and Intermediate Documents (IDocs). The SAP ERP (Financials) system sends cost center data to SAP SuccessFactors Employee Central using the middleware. This means that cost center replication is triggered by SAP ERP. You configure a Remote Function Call (RFC) outbound connection to enable the communication from SAP ERP to the middleware.

### Procedure

1. Copy the URL used for the communication from SAP ERP to the middleware from [Manage Integration Content > Endpoints](#) in SAP Cloud Integration.
2. Go to the *Configuration of RFC Connections* (SM59) transaction in your SAP ERP system.
3. Select the *HTTP Connections to External Server* (G) type and choose *Create*.
4. Make the technical settings.
  - In the *Target Host* field, enter the `<runtime URL of your SAP Cloud Integration environment>` part of the URL that you've copied in the first step.

- In the *Path Prefix* field, enter the `/cxf/<sender address>` part of the URL that you've copied in the first step.
5. Make the logon and security settings.
    - In the *Logon Procedure* section, select the *Basic Authentication* option.
    - In the *Logon* section, enter the user ID and password of your SAP Cloud Integration communication user.
  6. Test outbound connectivity from SAP ERP to SAP Cloud Integration.
    - a. Press the *Connection Test* button and enter your user ID and password.
 

You'll get an error. Don't worry, from a technical point of view everything is fine. You get this error message because the connection test can't fill the business content of the web service.
    - b. Go to the web-based monitoring in SAP Cloud Integration and check whether the cost center replication process was triggered.
 

Don't worry if the process runs into an error because the connection test didn't contain a valid payload. You'll know that the connectivity works when the process is triggered in SAP Cloud Integration after you've initiated the connection test from your SAP ERP system.

**Task overview:** [Configuration of SAP Cloud Integration for Cost Center Replication \[page 17\]](#)

**Previous task:** [Configuring the Language Table for Cost Center Replication \[page 28\]](#)

## 4.4 Field Mapping in the Middleware

Here's how IDoc nodes and attributes from SAP ERP are mapped to their Employee Central counterparts.

IDoc Node	IDOC Attribute	Employee Central Node	Employee Central Attribute
CostCenterData	REMOTE_OBJECT_ID	FO CostCenter	externalCode
CostCenterData	REMOTE_EXTERNAL_OBJECT_ID	FO CostCenter	costcenterExternalObjectID*
CostCenterAttribute	VALIDITY_PERIOD_START_DATE	FO CostCenter	start_date
CostCenterAttribute	VALIDITY_PERIOD_END_DATE	FO CostCenter	end_date
CostCenterAttribute	POSTING_ALLOWED_INDICATOR	FO CostCenter	status
CostCenterName	NAME_SHORT and LANGUAGE_CODE**	FO CostCenter	name<language_code>
CostCenterDescription	NAME and LANGUAGE_CODE**	FO CostCenter	description<language_code>

\* ExternalObjectID is only filled if you've set the `USE_EXTERNAL_COST_CENTER` parameter of the middleware process to **true**.

\*\* If you want to replicate translated descriptions and names of cost centers, map the language codes that you use in SAP ERP and Employee Central in the middleware process.

## 4.5 Monitoring in SAP Cloud Integration

Use the monitoring features of SAP Cloud Integration to check whether any issues occurred in your middleware processes.

SAP Cloud Integration provides a web-based monitoring UI that allows you to check the status of messages and integration content artifacts for a tenant cluster. For more information, see [Monitoring](#).

Use the log ID that you find in the monitoring to find the log of a specific process that didn't run successfully and to filter the log for detailed information.

## 4.6 Reporting Middleware Issues

Report a case if you have issues that you can't solve using the monitoring in SAP Cloud Integration, providing information about the process run.

### Context

If you face an issue with your SAP Cloud Integration-based integration scenario and want to report a case, enable the extended log to ensure that the data that's needed for analyzing the issue is written to the log.

#### Caution

For data protection reasons, enable the extended log for troubleshooting purposes only. Make sure that you disable the parameter again afterwards.

If you enable the extended log, the complete message payload containing all data that is to be transferred is stored in the log. Make sure that you configure permissions in a way that only authorized persons can view the payload in the log. Also ensure that you're compliant with the data protection and privacy regulations so that your data gets the highest level of protection.

For more information, refer to:

- [Data Protection and Privacy](#)
- [Identity and Access Management](#) and [Persona](#) for the Cloud Foundry Environment
- [Managing Users and Role Assignments](#) and [Persona](#) for the Neo Environment

## Procedure

1. Set the `ENABLE_PAYLOAD_LOGGING` parameter to **TRUE** in the configuration of the integration flow.
2. Run the integration.
3. Go to [Create a Support Case](#) and report a case for the LOD-SF-INT-CPI component.
4. Add the log ID from the payload to the case so that the support team can find the log easily.

## Next Steps

For the required information that you should add in your case, refer to the SAP Knowledge Base Article (KBA) [2763716](#).

# 5 Configuration of Cost Center Replication in the SAP ERP System

Make settings in your SAP ERP system to enable cost center replication to Employee Central.

## [Customizing Settings for Cost Center Replication \[page 37\]](#)

Find out about the Customizing settings you need to make in your SAP ERP system for cost center replication to Employee Central.

## [Enabling Change Pointers \[page 38\]](#)

Enable change pointers in the SAP ERP system to trigger cost center replication into Employee Central.

## [Configuration of ALE Distribution \[page 39\]](#)

Some configuration steps are needed to enable data distribution for cost centers using Application Link Enabling (ALE).

## 5.1 Customizing Settings for Cost Center Replication

Find out about the Customizing settings you need to make in your SAP ERP system for cost center replication to Employee Central.

To define customer-specific settings for the replication of cost centers, use the Customizing activities and Business Add-Ins (BADIs) provided with the integration add-on for SAP ERP CO master data with SAP SuccessFactors Employee Central (ODTFINCC software component). In the *SAP Customizing Implementation Guide* structure, open [▶ Controlling ▶ Integration of SAP ERP CO Master Data with SuccessFactors Employee Central ▶](#).

The following Customizing activities are provided in this structure:

Customizing Activity	Customizing Object	Use
<a href="#">Define File Path and Name for Storing the Generated Files</a>	View cluster FILENAME	Enter the physical file path and file name that, in your system, correspond to the logical file path and file name used by the <i>Extract Cost Centers from ERP for Replication to Employee Central</i> (ODTF_REPL_CC_CSV) program
<a href="#">▶ Business Add-Ins (BADIs) ▶ BAdI: CSV File Name Parameters ▶</a>	BAdI definition ODTF_CO_REPL_FILE_PARAMETERS	Fill the placeholders <PARAM_1>, <PARAM_2>, and <PARAM_3> for the physical file names of the <i>Extract Cost Centers from ERP for Replication to Employee Central</i> (ODTF_REPL_CC_CSV) program in a way other than the default

Customizing Activity	Customizing Object	Use
<a href="#">▶ Business Add-Ins (BAIs) ▶ BAdI: Modify Replication IDOC for Cost Centers ▶</a>	BAdI definition ODTF_CO_REPL_IDOC_COST_CENTERS	Change cost center data that is to be transferred with the intermediate document (IDoc) <i>ODTF_CCTR</i> to a subsystem
<a href="#">▶ Business Add-Ins (BAIs) ▶ BAdI: Modify Replication CSV File for Cost Centers ▶</a>	BAdI definition ODTF_CO_REPL_IDOC_COST_C_CSV	Change cost center data that is to be transferred with a Comma-Separated Values (CSV) file to a subsystem

The integration add-on also contains the *Extract Cost Centers from ERP for Replication to Employee Central* (ODTF\_REPL\_CC\_CSV) program. This program extracts cost center master data from the SAP ERP system into a CSV file, which can be used to import the data into Employee Central.

## 5.2 Enabling Change Pointers

Enable change pointers in the SAP ERP system to trigger cost center replication into Employee Central.

### Context

SAP ERP uses change pointers to track changes to master data objects. IDocs can be created for those changes and distributed through the SAP ERP and cloud landscape.

### Procedure

1. Go to the *Activate Change Pointers Generally* (BD61) transaction and make sure that that the *Change pointers activated - generally* checkbox is selected.
2. Go to the *Activate Change Pointers for Message Type* (BD50) transaction and enable change pointer creation for message type *ODTF\_CCTR* by selecting the *Active* checkbox.

## 5.3 Configuration of ALE Distribution

Some configuration steps are needed to enable data distribution for cost centers using Application Link Enabling (ALE).

Table 12: Configuration Steps Needed to Set Up ALE Distribution

Required Step	More Information
First you create a Remote Function Call (RFC) connection. The RFC enables calling and execution of predefined functions in a remote system. It manages the communication process, parameter transfer, and error handling.	You've already carried out this step when configuring the middleware. See section <a href="#">Enabling the SAP ERP Outbound Connection to the Middleware [page 33]</a> .
Then you define two logical systems, which represent the communication partners for the data transfer: your SAP ERP system and the middleware system. And you define a distribution model, which specifies that cost center data is to be transferred between these systems.	<a href="#">Configuring the Logical Systems and the Distribution Model [page 40]</a>
Next you create a port that uses the RFC connection you've created in the first step. The port is the channel by which the SAP ERP system can exchange data with the middleware.	<a href="#">Creating a Port for Data Exchange with the Middleware [page 40]</a>
Finally, you create a partner profile for the logical system that represents the receiver, meaning the middleware system. In this profile, you specify that the port you've created in the previous step is to be used for the communication. The partner profile defines the parameters for the data exchange with the middleware.	<a href="#">Creating a Partner Profile [page 41]</a>

### 5.3.1 Creating an RFC HTTP Connection

Create an RFC HTTP connection of type G (*HTTP Connection to External Server*).

#### Procedure

Create an RFC HTTP connection if you haven't done so yet when setting up the connection from the SAP ERP to the middleware.

#### Related Information

[Enabling the SAP ERP Outbound Connection to the Middleware \[page 33\]](#)

## 5.3.2 Configuring the Logical Systems and the Distribution Model

Define two logical systems, which represent the communication partners for the data transfer, and a distribution model, which specifies that cost center data should be transferred between these systems.

### Context

To make these settings, go to the `SALE` transaction and carry out the steps we describe below.

### Procedure

1. Choose **Basic Settings > Logical Systems > Define Logical Systems** and define two logical systems that represent your SAP ERP system and the middleware system.
2. Choose **Modelling and Implementing Business Processes > Maintain Distribution Model and Distribute Views** and define a distribution model for cost center data that connects the two logical systems you've created in the previous step:
  - a. Switch to the edit mode.
  - b. Choose *Create Model View*.
  - c. Enter a short text such as **ERP to EC Cost Center Replication** and a technical name such as **EC\_CC\_REPL** and choose *Enter*.
  - d. Select the model view you've just created and choose *Add Message Type*.
  - e. Make these entries, then choose *Enter*:
    - *Sender*: Select the logical system representing your SAP ERP system, as you've created it in the first step.
    - *Receiver*: Select the logical system representing your middleware system, as you've created it in the first step.
    - *Message Type*: Select **ODTF\_CCTR**.

## 5.3.3 Creating a Port for Data Exchange with the Middleware

Create a channel by which the SAP ERP system can exchange cost center data with the middleware.

### Context

This means you create a port of the XML HTTP type, which uses the RFC connection you've created before. To do this, go to the *Ports in IDoc Processing* (`WE21`) transaction and carry out the steps we describe below.



## Procedure

1. Select the *XML HTTP* node and choose *Create*.
2. Enter a name such as **CC\_HCI** and a description such as **ERP to EC Cost Center Replication**.
3. Select the RFC destination that you've created as described in section [Enabling the SAP ERP Outbound Connection to the Middleware \[page 33\]](#).
4. Select the *Application/x-sap.idoc* content type.
5. Select the *SOAP Protocol* checkbox.

## 5.3.4 Creating a Partner Profile

Create a partner profile for the logical system that represents the middleware system. In this profile, you specify that the port you've created in the previous step is to be used for the communication.

## Context

The partner profile defines the parameters for the data exchange with the middleware using the IDoc interface.

## Procedure

1. Go the *Partner Profiles* (WE20) transaction in your SAP ERP system.
2. Select the *Partner Type LS* node, choose *Create*, and fill in these fields:
  - *Partner Type*: **LS**
  - *Type* (on the *Post-Processing: Permitted Agent* tab): **US** (= user)
  - *Agent* (on the *Post-Processing: Permitted Agent* tab): User name of the replication user
3. In the *Partner No.* field, enter the name of the logical system representing your middleware system, as you've created it in the [Configuring the Logical Systems and the Distribution Model \[page 40\]](#) step.
4. Save your entries, then choose *Create Outbound Parameter* (the plus symbol) in the *Outbound Parameters* section.
5. Make these entries, then choose *Save*:
  - *Message Type*: Select **ODTF\_CCTR**.
  - *Receiver Port*: Select the port you've created as described in the [Creating a Port for Data Exchange with the Middleware \[page 40\]](#) step.
  - *Basic Type* (in the *IDoc Type* section): Select **ODTF\_CCTR01**.

# 6 Replication of Cost Centers to Employee Central

Look at the business logic of cost center replication from SAP ERP to Employee Central, some use cases, and how you run the replication.

## [Business Logic of Cost Center Replication \[page 42\]](#)

See what cost centers are, what they're used for, and how they're mapped in SAP ERP and Employee Central.

## [Use Cases of Cost Center Replication \[page 44\]](#)

Look at some use cases of cost center replication from SAP ERP to Employee Central.

## [Configuration of the Cost Center Replication Program for Initial Replication \[page 45\]](#)

Learn more about the settings you make on the selection screen of the replication program if you want to trigger initial replication of cost centers from SAP ERP to Employee Central.

## [Configuring and Running Delta Replication \[page 47\]](#)

Take a look at setting up delta replication of cost centers from SAP ERP to Employee Central.

## [Replicating Translated Cost Center Texts \[page 47\]](#)

Make settings to replicate translated descriptions and names of cost centers to Employee Central.

## [User Exits for Cost Center Replication \[page 48\]](#)

In case you want to modify cost center data before it's transferred to Employee Central, you can use the Business Add-Ins (BAdIs) of the `ODTF_CC_REPLICAT_IDOCS_MODIFY` enhancement spot.

## 6.1 Business Logic of Cost Center Replication

See what cost centers are, what they're used for, and how they're mapped in SAP ERP and Employee Central.

Cost centers are generic objects (also known as MDF objects) in Employee Central. They're effective dated like any other master data object in Employee Central. Cost centers are used for employee assignments as well as in alternative cost distributions.

For more information about how to replicate cost center assignments from Employee Central to SAP ERP, see the [Replicating Employee Master Data and Organizational Assignments from Employee Central to SAP ERP HCM](#) implementation guide. Find the most current version of this guide at [http://help.sap.com/hr\\_ecintegration](http://help.sap.com/hr_ecintegration).

### [Lock Flags Controlling the Posting to Cost Centers \[page 43\]](#)

Lock flags can be set in SAP ERP to prevent posting to a cost center. Setting a lock flag results in a status change in Employee Central.

### [Cost Center Key Mapping \[page 44\]](#)

Whenever there are multiple SAP ERP systems you need to make sure that the cost center IDs delivered to Employee Central are unique across your system landscape.

# 6.1.1 Lock Flags Controlling the Posting to Cost Centers

Lock flags can be set in SAP ERP to prevent posting to a cost center. Setting a lock flag results in a status change in Employee Central.

A cost center in SAP ERP has control flags to control the behavior of the cost center in financial processes.

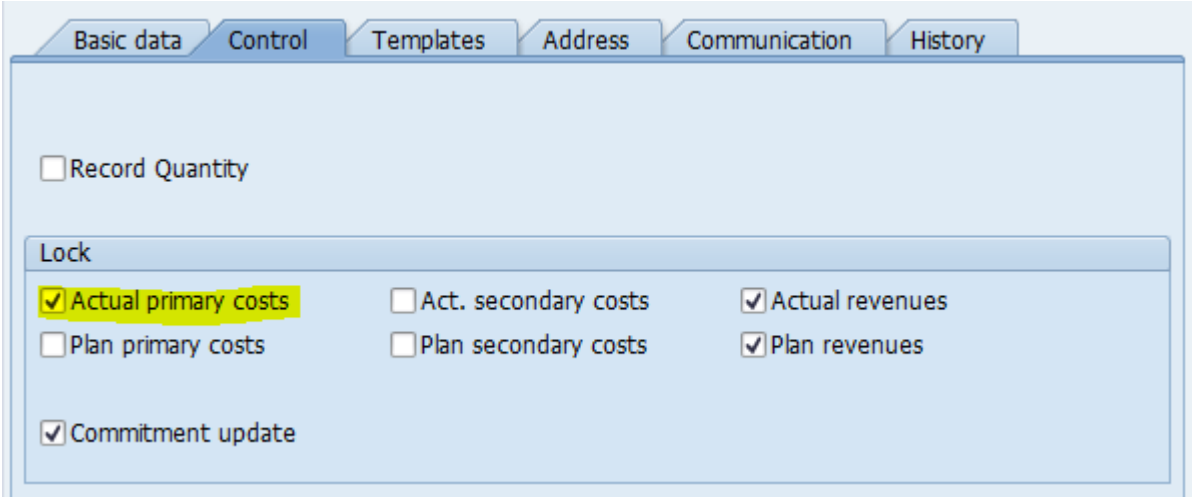

Figure 5: Cost Center Control Flags

One of these flags is *Actual primary costs*. In Employee Central, this flag is mapped to the status of the cost center:

- If the lock flag isn't set in SAP ERP, the status of the cost center is *Active* in Employee Central.
- If the lock flag is set in SAP ERP, the status of the cost center is *Inactive* in Employee Central.

The integration doesn't check for dependent data in Employee Central, so updates can interfere with existing data. For example, a lock flag is set for a cost center that is still assigned to employees in Employee Central. Setting the lock flag sets the Employee Central status to *Inactive*. This issue is recognized by the system. An *Invalid Cost Center* admin alert is created. The issue has to be resolved by the administrator.

### ❖ Example

In this example, a lock flag has been set for the *ALE\_00001* cost center as of January 1, 2019. Two employees are associated with the cost center. The system indicates the issue.

Table 13: Example: Admin Alert in Employee Central

Employee Name	Effective Date	Current Invalid Data Value	Invalid Effective Date
Judy Hoffman(jhoffman1)	07/01/2018 – 12/31/9999	Re-search(2000ALE_000001)	01/01/2019 – 12/31/9999
Paul Mike Lopez(plopez)	08/26/2018 – 12/31/9999	Re-search(2000ALE_000001)	01/01/2019 – 12/31/9999

## 6.1.2 Cost Center Key Mapping

Whenever there are multiple SAP ERP systems you need to make sure that the cost center IDs delivered to Employee Central are unique across your system landscape.

The default ID delivered by SAP ERP is a concatenation of controlling area key (4 characters) and cost center key (not more than 10 characters). The controlling area key is required to make the ID unique (because different cost centers can have the same key if they belong to different controlling areas). If the concatenated ID is not unique, you need to implement the Business Add-Ins (BADIs) of the `ODTF_CC_REPLICAT_IDOCS_MODIFY` enhancement spot:

- BAdI *Modify Replication IDOC for Cost Centers* (`ODTF_CO_REPL_IDOC_COST_CENTERS`) for IDocs
- BAdI *Modify Replication CSV File for Cost Centers* (`ODTF_CO_REPL_IDOC_COST_C_CSV`) for files

You'll find these BADIs in the Customizing structure.

### Related Information

[Customizing Settings for Cost Center Replication \[page 37\]](#)

## 6.2 Use Cases of Cost Center Replication

Look at some use cases of cost center replication from SAP ERP to Employee Central.

### General

Whenever a cost center is created or changed, a change pointer is created. The change pointer processing (batch job `RBDMIDOC`) creates the IDoc for the change pointers of those cost centers that fulfill the selection criteria defined in the variant used for delta replication in the `ODTF_REPL_CC` program, and sends it to Employee Central.

### Creating New Cost Center

The cost center data is replicated accordingly to Employee Central. If the cost center isn't locked for posting, the status is *Active*.

## Changing Existing Cost Center

If a new record is created in the SAP ERP system, this record is replicated accordingly to Employee Central.

## Locking Cost Center (Disable Posting to Cost Center)

If a cost center is locked, the status in Employee Central is changed from *Active* to *Inactive*.

## Deleting Cost Center

If a cost center is deleted in the SAP ERP system, the deletion isn't transferred to Employee Central. You must delete the cost center manually in the Employee Central system.

## 6.3 Configuration of the Cost Center Replication Program for Initial Replication

Learn more about the settings you make on the selection screen of the replication program if you want to trigger initial replication of cost centers from SAP ERP to Employee Central.

Initial replication is handled by the `ODTF_REPL_CC` program. Run the *ABAP: Program Execution* (SA38) transaction and execute the program. On the selection screen, define your replication criteria as required.

Some sections of the selection screen require additional explanation:

### Responsible Manager

*Set Responsible Manager in BAdI*: If this option is selected, you must implement the `ODTF_CO_REPL_IDOC_COST_CENTERS` Business Add-In (BAdI) to set the employee ID of the person responsible.

#### **i** Note

In the standard middleware process, the manager isn't mapped to the cost center manager in Employee Central. If you need the manager in Employee Central, you have to extend the standard process with this mapping.

## Settings for Description

*Replicate all languages (only supported for replication to Employee Central)*: Select this checkbox if you want to replicate translated descriptions and names of cost centers from SAP ERP to Employee Central.

### i Note

If you select this checkbox, you need to map the languages that you use in SAP ERP and Employee Central in the middleware.

## Delta Replication Settings

Ignore these settings for initial replication.

## Transfer of Historic Data as Of

*Start Date*: Determines the validity start date of the cost centers. The validity of the cost center must match the validity of an employee record. Otherwise, the cost center doesn't show up in the job information of the employee. Don't change the transmission start date after initial replication. You risk invalidating your employee cost center assignments in Employee Central.

## Processing Mode

- *Write Error Log for Skipped Data Sets*  
If this option is selected, any data sets that aren't replicated will be logged in the program list.
- *Test Mode (List Selected Data Only)*  
Enabled by default. If this option is selected, no data is replicated to the target system. The program shows a list of the data records that would have been replicated.

## Related Information

[Configuring the Language Table for Cost Center Replication \[page 28\]](#)

## 6.4 Configuring and Running Delta Replication

Take a look at setting up delta replication of cost centers from SAP ERP to Employee Central.

### Context

Delta replication of cost centers is handled by the `ODTF_REPL_CC` program. Here's what you need to do:

### Procedure

1. On the selection screen, define your replication criteria as required and select the *Use Variant for Delta Replication Using Change Pointers* checkbox to specify that you want to use this program variant for the replication of changes. Then save your selection as variant.
2. Go to the *Define Background Job* (SM36) transaction and schedule the *Creating IDoc Type from Change Pointers* (RBDMIDOC) program as a regular background job using the `ODTF_CCTR` message type.

The RBDMIDOC program reads the change pointers with the `ODTF_CCTR` message type and replicates the changed data using the `ODTF_REPL_CC` program variant that you've defined in the first step.

### Related Information

[Enabling Change Pointers \[page 38\]](#)

## 6.5 Replicating Translated Cost Center Texts

Make settings to replicate translated descriptions and names of cost centers to Employee Central.

### Procedure

1. Map the languages that you use in SAP ERP and Employee Central in the middleware process, using the *Map Cost Center Language Keys from SAP ERP or SAP S/4HANA to Language Keys from SAP SuccessFactors Employee Central* value mapping.
2. Select the *Replicate all languages (only supported for replication to Employee Central)* checkbox on the selection screen of the `ODTF_REPL_CC` program.

## Related Information

[Configuring the Language Table for Cost Center Replication \[page 28\]](#)

## 6.6 User Exits for Cost Center Replication

In case you want to modify cost center data before it's transferred to Employee Central, you can use the Business Add-Ins (BAdIs) of the `ODTF_CC_REPLICAT_IDOCS_MODIFY` enhancement spot.

The enhancement spot contains the following BAdIs:

- *Modify Replication IDOC for Cost Centers* (`ODTF_CO_REPL_IDOC_COST_CENTERS`) for IDocs
- *Modify Replication CSV File for Cost Centers* (`ODTF_CO_REPL_IDOC_COST_C_CSV`) for files

The interfaces of both BAdIs offer a method to modify the data. You have full access to the IDoc data. In case you need to create unique IDs, you can modify the attribute `REMOTE_EXTERNAL_OBJECT_ID` with an ID compiled by an algorithm that fits your needs.

Find these BAdIs in the Customizing structure.

## Related Information

[Customizing Settings for Cost Center Replication \[page 37\]](#)



# 7 You're done! What's Next?

You've set up cost center replication to Employee Central – now go through the follow-up steps.

[Performance Optimization of This Integration \[page 49\]](#)

Here are some best practices to help you improve the performance of cost center replication.

## 7.1 Performance Optimization of This Integration

Here are some best practices to help you improve the performance of cost center replication.

Cost center replication sends data packages asynchronously from SAP ERP to Employee Central using the middleware.

### Package Size

Since data is sent asynchronously, there's no risk of large package sizes causing timeouts. Cost center replication has a fixed package size of 1000, which you can't change.

### Parallelization

You could parallelize cost center replication by deploying the integration process multiple times in the middleware and creating multiple sets of configuration in your SAP ERP system to differentiate them between these processes. But since creating or updating cost centers in Employee Central doesn't take much time, parallelization wouldn't improve the performance significantly. That's why we don't recommend parallelizing cost center replication processes.

### Delta Replication

In contrast, the delta replication mode, which is based on change pointers, significantly improves performance. That's why we recommend using it.

## Logging

We recommend disabling payload logging in the middleware. Only enable payload logging if an issue occurs in cost center replication, to be able to analyze the problem.

## General Recommendations

Check your firewall and proxy for restrictions on the maximum package size. If necessary, adjust the firewall and proxy settings or the package size according to your integration.

Deactivate integration processes that you no longer use.

By the latest when you switch from your development and test environment to your production environment, disable all integrations that you have set up for development and testing purposes. Trigger them only on demand.

Check whether an integration really needs to run 24/7. For some data types it might be sufficient to replicate only from time to time. You can increase the time interval for the affected processes to replicate this data less frequently.

If an error occurs during the integration, stop the scheduler. It does not make sense to continue a replication that constantly generates error messages. Running the replication merely overloads the logs and makes error analysis more difficult.

# Change History

Learn about changes to the documentation for Replicating Cost Centers from SAP ERP to Employee Central in recent releases.

## 2H 2023

Type of Change	Description	More Info
Changed	We have moved the Change History to the end of the guide.	<a href="#">Introduction to Cost Center Replication [page 4]</a>
Changed	We've added a recommendation to use integration of SAP SuccessFactors Employee Central with SAP Master Data Integration to replicate cost centers from SAP ERP to Employee Central when you start a new integration project.	<a href="#">Introduction to Cost Center Replication [page 4]</a>
Changed	We've removed the following versions of the SAP_BASIS software component from the required components: <ul style="list-style-type: none"><li>• 710 with SP15 or a higher SP</li><li>• 711 with SP10 or a higher SP</li><li>• 730 with SP03 or a higher SP</li></ul> These versions are no longer supported. For more information, refer to SAP Note <a href="#">1648480</a> .	<a href="#">Checking the Minimum Setup Required for Your Systems [page 7]</a>

## 2H 2022 – 1H 2023



Type of Change	Description	More Info
None	We did not update this document.	

# Important Disclaimers and Legal Information

## Hyperlinks

Some links are classified by an icon and/or a mouseover text. These links provide additional information.

About the icons:

- Links with the icon : You are entering a Web site that is not hosted by SAP. By using such links, you agree (unless expressly stated otherwise in your agreements with SAP) to this:
  - The content of the linked-to site is not SAP documentation. You may not infer any product claims against SAP based on this information.
  - SAP does not agree or disagree with the content on the linked-to site, nor does SAP warrant the availability and correctness. SAP shall not be liable for any damages caused by the use of such content unless damages have been caused by SAP's gross negligence or willful misconduct.
- Links with the icon : You are leaving the documentation for that particular SAP product or service and are entering an SAP-hosted Web site. By using such links, you agree that (unless expressly stated otherwise in your agreements with SAP) you may not infer any product claims against SAP based on this information.

## Videos Hosted on External Platforms

Some videos may point to third-party video hosting platforms. SAP cannot guarantee the future availability of videos stored on these platforms. Furthermore, any advertisements or other content hosted on these platforms (for example, suggested videos or by navigating to other videos hosted on the same site), are not within the control or responsibility of SAP.

## Beta and Other Experimental Features

Experimental features are not part of the officially delivered scope that SAP guarantees for future releases. This means that experimental features may be changed by SAP at any time for any reason without notice. Experimental features are not for productive use. You may not demonstrate, test, examine, evaluate or otherwise use the experimental features in a live operating environment or with data that has not been sufficiently backed up.

The purpose of experimental features is to get feedback early on, allowing customers and partners to influence the future product accordingly. By providing your feedback (e.g. in the SAP Community), you accept that intellectual property rights of the contributions or derivative works shall remain the exclusive property of SAP.

## Example Code

Any software coding and/or code snippets are examples. They are not for productive use. The example code is only intended to better explain and visualize the syntax and phrasing rules. SAP does not warrant the correctness and completeness of the example code. SAP shall not be liable for errors or damages caused by the use of example code unless damages have been caused by SAP's gross negligence or willful misconduct.

## Bias-Free Language

SAP supports a culture of diversity and inclusion. Whenever possible, we use unbiased language in our documentation to refer to people of all cultures, ethnicities, genders, and abilities.



© 2023 SAP SE or an SAP affiliate company. All rights reserved.

No part of this publication may be reproduced or transmitted in any form or for any purpose without the express permission of SAP SE or an SAP affiliate company. The information contained herein may be changed without prior notice.

Some software products marketed by SAP SE and its distributors contain proprietary software components of other software vendors. National product specifications may vary.

These materials are provided by SAP SE or an SAP affiliate company for informational purposes only, without representation or warranty of any kind, and SAP or its affiliated companies shall not be liable for errors or omissions with respect to the materials. The only warranties for SAP or SAP affiliate company products and services are those that are set forth in the express warranty statements accompanying such products and services, if any. Nothing herein should be construed as constituting an additional warranty.

SAP and other SAP products and services mentioned herein as well as their respective logos are trademarks or registered trademarks of SAP SE (or an SAP affiliate company) in Germany and other countries. All other product and service names mentioned are the trademarks of their respective companies.

Please see <https://www.sap.com/about/legal/trademark.html> for additional trademark information and notices.