

# Measuring Points and Counters (PM-EQM-SF-MPC)



HELP.P.MEQMEQ

**Release 4.6B**



## Copyright

© Copyright 2000 SAP AG. All rights reserved.

No part of this brochure may be reproduced or transmitted in any form or for any purpose without the express permission of SAP AG. The information contained herein may be changed without prior notice.

Some software products marketed by SAP AG and its distributors contain proprietary software components of other software vendors.

Microsoft®, WINDOWS®, NT®, EXCEL®, Word® and SQL Server® are registered trademarks of Microsoft Corporation.

IBM®, DB2®, OS/2®, DB2/6000®, Parallel Sysplex®, MVS/ESA®, RS/6000®, AIX®, S/390®, AS/400®, OS/390®, and OS/400® are registered trademarks of IBM Corporation.

ORACLE® is a registered trademark of ORACLE Corporation, California, USA.

INFORMIX®-OnLine for SAP and Informix® Dynamic Server™ are registered trademarks of Informix Software Incorporated.

UNIX®, X/Open®, OSF/1®, and Motif® are registered trademarks of The Open Group.

HTML, DHTML, XML, XHTML are trademarks or registered trademarks of W3C®, World Wide Web Consortium, Laboratory for Computer Science NE43-358, Massachusetts Institute of Technology, 545 Technology Square, Cambridge, MA 02139.

JAVA® is a registered trademark of Sun Microsystems, Inc., 901 San Antonio Road, Palo Alto, CA 94303 USA.

JAVASCRIPT® is a registered trademark of Sun Microsystems, Inc., used under license for technology invented and implemented by Netscape.

SAP, SAP Logo, mySAP.com, mySAP.com Marketplace, mySAP.com Workplace, mySAP.com Business Scenarios, mySAP.com Application Hosting, WebFlow, R/2, R/3, RIVA, ABAP, SAP Business Workflow, SAP EarlyWatch, SAP ArchiveLink, BAPI, SAPPHIRE, Management Cockpit, SEM, are trademarks or registered trademarks of SAP AG in Germany and in several other countries all over the world. All other products mentioned are trademarks or registered trademarks of their respective companies.

## Icons

Icon	Meaning
	Caution
	Example
	Note
	Recommendation
	Syntax
	Tip

## Contents

<b>Measuring Points and Counters (PM-EQM-SF-MPC)</b> .....	<b>5</b>
<b>Measuring Point</b> .....	<b>7</b>
<b>Counter</b> .....	<b>11</b>
<b>Measurement Document</b> .....	<b>13</b>
<b>Counter-Based Maintenance</b> .....	<b>14</b>
<b>Condition-Based Maintenance</b> .....	<b>16</b>
<b>Customer Exit IMRC0001</b> .....	<b>18</b>
Calling up Documentation for the Exit .....	20
<b>Entering Measurement and Counter Readings</b> .....	<b>21</b>
<b>Entering Measurement and Counter Readings as Barcodes</b> .....	<b>23</b>
<b>Basic Functions</b> .....	<b>26</b>
<b>Creating Measuring Points and Counters</b> .....	<b>27</b>
Creating Measuring Points When Processing a Technical Object .....	29
Creating a Measuring Point Directly .....	31
Creating Counters When Processing a Technical Object .....	32
Creating a Counter Directly .....	34
Classifying a Measuring Point/Counter .....	35
Defining a Measurement Range .....	36
<b>Processing Measuring Points and Counters</b> .....	<b>37</b>
<b>Creating Measurement Documents</b> .....	<b>39</b>
<b>Processing Measurement Documents</b> .....	<b>41</b>
Example for Reversing a Measurement Document .....	44
<b>Additional Functions</b> .....	<b>45</b>
<b>Transfer of Measurement and Counter Readings</b> .....	<b>46</b>
Defining Data for a Measurement/Counter Reading Transfer .....	50
Repeating a Measurement or Counter Reading Transfer .....	51
Defining a Measurement/Counter Reading Transfer for Copied Location Structures .....	52
Displaying the Transfer Hierarchy for a Key Date .....	53
<b>Working With a Measurement Reading Entry List</b> .....	<b>54</b>
<b>Setting the Total Counter Reading Externally</b> .....	<b>55</b>
<b>Representing Counter Replacement</b> .....	<b>56</b>
<b>Converting Units of Measurement</b> .....	<b>57</b>
Using the Conversion Function .....	59

## Measuring Points and Counters (PM-EQM-SF-MPC)

### Purpose

You use this component in *Plant Maintenance* (PM) or *Customer Service* (CS) to enter measurement and counter readings for [technical objects \[Ext.\]](#). This can be of use in the following situations:

- You want to document the condition of a technical object at a particular point in time.  
Documenting the condition of a particular object is of great importance in cases where detailed records regarding the correct condition have to be kept for legal reasons. This could involve critical values recorded for environmental protection purposes, hazardous working areas that are monitored for health and safety reasons, the condition of equipment in hospitals (intensive care units), as well as measurements of emissions and pollution for objects of all types.
- You want to perform [counter-based maintenance \[Page 14\]](#).  
Condition and counter-based maintenance tasks are forms of preventive maintenance. Generally, these tasks should reduce the number of breakdowns for your objects.  
In the case of counter-based maintenance, maintenance activities are always performed when the counter of the technical object has reached a particular counter reading, for example, every 100 operating hours.
- You want to perform [condition-based maintenance \[Page 16\]](#).  
In the case of condition-based maintenance, maintenance activities are always performed when the measuring point of a technical object has reached a particular state, for example, every time a brake pad has been worn away to the minimum thickness permitted.

### Integration

This component is composed as follows:

- You enter data manually into the R/3 System using the R/3 user interface.
- You use the [Internet Application Component \[Ext.\]](#) (IAC) to enter data in an entry screen in the browser and transfer this data to the R/3 System using the Internet.
- You can enter data using a [barcode \[Page 23\]](#) reader and transfer it to the R/3 System using the [PM-PCS interface \[Ext.\]](#).  
The PM-PCS Interface is an interface between the R/3 System and external systems, such as a Process Control System (PCS).
- You can enter data using a laptop and transfer it to the R/3 System using the PM-PCS Interface.
- Data from a process control system is data that arises during the monitoring, control, regulation, and optimization of a technical process. You can transfer this data to the R/3 System using the PM-PCS Interface.

When transferring data, you can use a SCADA System (Supervisory Control and Data Acquisition System) which filters the data from the process control system and only transfers the data that is actually relevant to the R/3 System.

## Measuring Points and Counters (PM-EQM-SF-MPC)

- You can use the [customer exit \[Page 18\]](#) to automate your business processes.

### Overview of all Elements of the Component *Measuring Points and Counters*

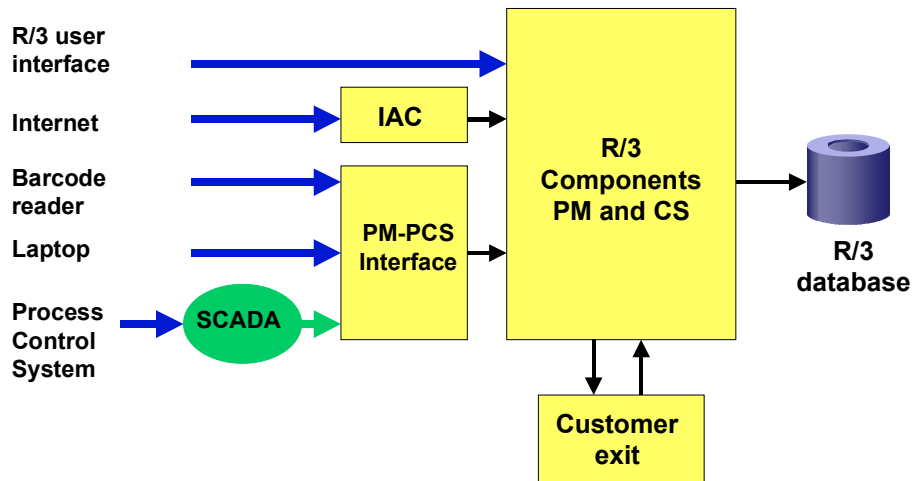

For more information on the maintenance planning functions in the R/3 System (for example, creating a maintenance plan, scheduling) see [Maintenance Planning \[Ext.\]](#).

## Features

Within the R/3 components PM and CS, the component *Measuring Points and Counters* is divided into:

- [Basic functions \[Page 26\]](#), which are the prerequisites for using measuring points and counters
- [Additional functions \[Page 45\]](#), whose use is optional

## Measuring Point

### Definition

Measuring points in the R/3 System describe the physical and/or logical locations at which a condition is described, (for example, the coolant temperature in a nuclear power station after the coolant has left the pressure vessel, or the number of revolutions at a rotor shaft of a wind-driven power plant).

In Plant Maintenance, measuring points are located on technical objects, in other words, on pieces of equipment or functional locations. For example, in a storeroom for fruit, a certain room temperature has to be created and maintained. The temperature is kept constant by a regulator, and is also checked regularly by a measuring device. The storeroom is represented in the system as functional location SR1-FR2. The temperature measuring device is then created as measuring point 23 for functional location SR1-FR2.

### Use

Measurement readings are taken at measuring points in particular measurement units at particular intervals. For example, the temperature in degrees Celsius of the coolant in the coolant pipe that leaves the pressure vessel at the nuclear power station, or the number of revolutions per minute at the rotor shaft of the wind-driven power plant.

Measurement readings describe a condition at a measuring point at a particular point in time, and represent the transaction data for measuring points in the R/3 System. They are documented in the form of [measurement documents \[Page 13\]](#).

In many cases, there may be an optimum value for a particular measuring point to which the device concerned is calibrated. You can specify this measurement reading as a **target value** for the measuring point.

You can enter measurement readings in three different forms:

Valuation	Use	Example
Quantitative	The current reading measured is entered in the system. The unit of the measurement reading (degrees Celsius in the above example) is defined by the characteristic in the master record of the measuring point.	February 2, 2000, 14.00: 25 degrees Celsius
Qualitative	A valuation code is entered in the system that gives the meaning of the current reading measured.  You can only enter a solely qualitative valuation if you have specified this in the system explicitly for the measuring point concerned.	February 2, 2000, 14.00: Temperature is normal

**Measuring Point**

This is a combination of a quantitative and qualitative valuation.	The current reading measured is entered in the system together with a valuation code.	February 2, 2000, 14.00: 25 degrees Celsius Temperature is normal
--	---	---

**Structure**

To enable you to differentiate more easily between the individual measuring points and provide them with a unit, you assign each measuring point to a characteristic from the classification system.

You can only use characteristics that are numerical and to which a unit (for example, 'degrees Celsius', or 'millimeters') has been assigned. You can use the characteristics to evaluate similar measuring points.

**Measuring Point Category**

Before you can create measuring points or counters, the valid measuring point categories must be defined in Customizing for *Measuring Points, Counters and Measurement Documents*.

For many measuring points, the same measuring point attributes are valid. For example, the number of the measurement position might have to be unique for each client, and a particular catalog type for code groups is valid for all measuring points. Measuring points are grouped in the system by measuring point category. Each measuring point category is identified by a key, which is the first thing you assign to the measuring point when you create it in the system.

You might have the following measuring point categories in a system:

Measuring Point Category	Attributes
<p><b>B</b></p> <p>Measuring points whose values are read by users</p>	<ul style="list-style-type: none"> <li>• Time of measurement reading cannot lie in the future</li> <li>• Measurement position must be unique for each object</li> <li>• Catalog type 9</li> <li>• Warning in the event of readings above/below the measurement range</li> </ul>
<p><b>A</b></p> <p>Measuring points whose values are transferred automatically from process control systems</p>	<ul style="list-style-type: none"> <li>• Time of measurement can lie up to two hours in the future</li> <li>• Measurement position number must be unique for the whole client</li> <li>• Catalog type 9</li> <li>• Error in the event of readings above/below the measurement range</li> </ul>

## Measurement Position

Measuring points are uniquely identified by the numbers that they are assigned internally. Since this number is not descriptive, you have the option of giving the measuring point a text or a descriptive number to describe the position of a measuring point at a technical object. You can do this in the field *MeasPosition* in the master record of the measuring point.

Measuring Point	Measurement Position	Description
261	P-FR	Front right tire
262	P-FL	Front left tire

The overview of an object's measuring points is always sorted by the system on the basis of the measurement position. You can change the entry in the field *MeasPosition* at any time, for example, if you determine after a few months that a particular measurement position at which measurements are taken very frequently is too far down the list.

The entry in the field *MeasPosition* only needs to be unique if this has been defined in Customizing for your system. In Customizing, you can define that the measurement positions of a measuring point category:

- Can be entered without a check for uniqueness
- Must be unique for each technical object
- Must be unique within a client

## Measurement Range

The measurement range represents the values that a measuring instrument or counter can display. For example, a thermometer can measure temperatures in a measurement range between -20 and +45 degrees Celsius, or a tape measure can measure lengths in a measurement range between 0 and 10 meters.

## Measurement Range Limit

In the case of **measuring points**, you can define that only readings that fall between the upper and lower limits are possible. If, for example, the thermometer in your company can only display temperatures in a measurement range between -20 and +45 degrees Celsius, a measurement reading of 90 degrees Celsius is outside the measurement range limit.

In the case of **counters**, the measurement range limits do not apply to the counter readings that are read, but to the total counter reading determined by the system. For example, a milometer can display values from 0 to 99,999. Since vehicles of this category have an expected life of 200,000 miles as a general rule, a counter overflow will occur several times before this total counter reading is reached. The employee responsible will enter a measurement range of 0 to 200,000 for the milometer.

You can define in Customizing for *Measuring Points, Counters and Measurement Documents* that the system issues a warning or an error message in the event of the measurement falling outside the measurement range. If you use the [customer exit IMRC0001 \[Page 18\]](#), you can trigger a follow-on event that you have defined when the measurement range is exceeded, such as the creation of a notification or an order.

---

**Measuring Point****Measurement Range Unit**

You use the measurement range unit to define the unit in which the measurement is made by the measuring instrument. This unit does not have to correspond to the unit of the characteristic that you have assigned to the measuring point or counter. However, it must share the same dimension in order that the system can convert the entry in the measurement document into the unit of measure of the characteristic. If you have, for example, assigned a characteristic with the unit “degrees Celsius” to a measuring point, you can enter “degrees Fahrenheit” as the measurement range unit, if this is the unit of the thermometer being used. However, units such as “meters” or “kilograms” are not possible in this case, as they do not belong to the same dimension “temperature”.

## Counter

### Definition

Tools that you use to represent the wear and tear of an object, consumption, or the reduction of an object's useful life are described as counters in the R/3 System (for example, the milometer for a vehicle, or an electricity meter for an electric-powered system).

In Plant Maintenance, counters are located on technical objects, in other words, on pieces of equipment or functional locations. For example, in the reservoir of a clarification plant, the volume of sewage that flows out of the drainage channels into this reservoir is measured in m<sup>3</sup>. The filtering tank is represented in the system as functional location C1-BR1. The waste water counter is designated as a counter 12 for functional location C1-BR1.

Counters form the basis for [counter-based maintenance \[Page 14\]](#).

### Use

Counter readings are taken at counters at particular intervals and in particular measurement units. For example, counter readings for kilometers driven or electricity used.

Counter readings describe a status at a counter at a particular point in time, and represent the transaction data for counters in the R/3 System. They are documented in the form of [measurement documents \[Page 13\]](#).

Counters are a special form of [measuring point \[Page 7\]](#) because over the course of time, counter readings only either continuously rise or fall. Counter overflow is also possible in the case of most counters. For example, a milometer can display a maximum value of 99,999 miles. Once this reading has been reached, an overflow occurs, in other words, the counter starts to count upwards from 00,000 again.

Counter readings can be entered in the system in two different ways. In both cases, a qualitative valuation is made:

- The **absolute counter reading** is entered in the system as the counter reading that the counter is currently displaying (for example, 02.01.2000, 14.00, 48,200 miles).
- The **counter reading difference** between the last reading and the current reading is entered in the system (for example, 02.01.2000, 14.00, 200 (additional) miles).

As with measurement readings, you can also enter a qualitative valuation for counter readings, using a valuation code (for example, 02.01.2000, 14.00, 48,200 miles, above-average increase of milometer reading).

You cannot make a solely qualitative valuation in the case of counters.

If you are dealing with counter-based maintenance, you can display the maintenance plans in which a counter is used in the master record of that counter. You have the following options for doing this:

- In the list of measuring points and counters, select the required counter and choose *Environment* → *Usage in MaintPlans*.
- In the detail screen of general data for the counter, choose *Environment* → *Usage in MaintPlans*.

Counter

## Measurement Document

### Definition

The data transferred to the system after a measurement has been taken at a measuring point or a counter is described in the R/3 System as a measurement document. This transfer can be performed automatically or manually. The measurement document is therefore the result of a measurement or counter reading being entered in the system.

### Structure

A data record for a measurement document comprises the following groups of data:

- Measuring point data  
This includes measuring point number, measurement position, description, characteristic and unit.
- Measurement result data  
This includes the time of the measurement or reading (time stamp) to the exact second, the measurement or counter reading, and any qualitative judgment regarding the result of the measurement.
- Possible additional information (as short and long text)  
This includes information about which employee who took the measurement or counter reading, and where necessary, the number of the measurement document from which the measurement or counter reading result has been copied.

You can also assign a **processing status** to the measurement document. This can indicate whether:

- Action must be taken as a result of the measurement or counter reading being taken
- The action to be taken as a result of the measurement or counter reading is already covered by a planned maintenance task

The system records both the entries converted to the unit of the characteristic and the **original entries** of the user, that may have been made in a different unit to that of the characteristic unit. This enables you to check later on, whether unusual values are the result of entries made incorrectly or conversion errors.

If you change a measurement document, the system saves your changes in the form of **change documents**. The measurement document also contains the user who created it and the user who last changed it in its **administrative data**. You can only change the processing status, and the short or long text.

You can **archive** measurement documents in the same way as a normal R/3 object.

---

**Counter-Based Maintenance**

## Counter-Based Maintenance

### Purpose

In the case of counter-based maintenance, maintenance activities are performed when the counter of the technical object has reached a particular counter reading, for example, every 100 operating hours. Counter-based maintenance can be employed for technical systems within the process, energy supply, or aviation industries.

### Process Flow

The following example describes a process scenario.

You want to check the washers of a pump every time 50,000 liters of water have flowed through it. The pump is represented in the R/3 System as a piece of [equipment \[Ext.\]](#). The equipment has a counter that measures the volume of water that flows through it. The maintenance of the equipment is based on a performance-based maintenance plan. This maintenance plan is linked to a task list in which all necessary operations for checking the washers are recorded.

In this example, the system creates a maintenance order with the operations from the task list. However, a maintenance notification, service order, or a service notification can also be created.

1. You create a measuring point for the piece of equipment "Pump". For more information, see [Creating Measuring Points and Counters \[Page 27\]](#).
2. You create a measurement document for this measuring point. This document serves as an initial document, meaning that all further counter readings or counter reading differences are calculated on the basis of this measurement document.
3. The system calculates the planned date by which 50,000 liters must have flowed through the pump. Your technician should check the washers on this planned date.
4. The system then calculates the call date on which the maintenance order is created. You have defined the call date before the planned date, so that you will have enough time to schedule and dispatch a technician.
5. You create further measurement documents over the course of time. The volume of water flowing through the pump increases.
6. Each time you create a new measurement document, the system recalculates the planned date.
7. The call date is reached when 48,500 liters have flowed through the pump and the system generates a maintenance order with the data from the task list.
8. Because the system created the maintenance order in good time, your technician can check the pump when the volume has reached 50,000 liters.

**Creating a Maintenance Order for Counter-Based Maintenance**

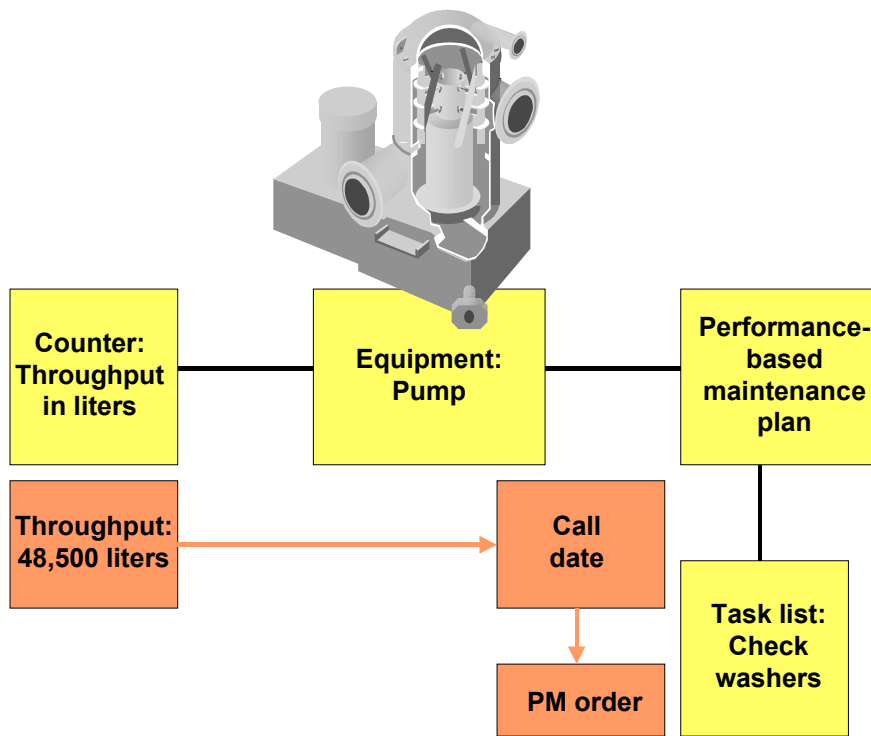

For more information on the maintenance planning functions in the R/3 System (for example, creating a maintenance plan, performing scheduling) see [Maintenance Planning \[Ext.\]](#).

---

**Condition-Based Maintenance**

## Condition-Based Maintenance

### Purpose

In the case of condition-based maintenance, maintenance activities are always performed when the measuring point of a technical object has reached a particular state, for example, every time a brake pad has been worn away to the minimum thickness permitted.

### Prerequisites

In the following example process, you use the [PM-PCS Interface \[Ext.\]](#) and the [customer exit IMRC0001 \[Page 18\]](#). The PM-PCS Interface is an interface between the R/3 System and external systems such as a Process Control System (PCS).

### Process Flow

The following example describes a process scenario.

You use a building control system to monitor a building's air conditioning system. You use a SCADA system (Supervisory Control And Data Acquisition system) that recognizes events that you have predefined. You define one of the events so that the drop in pressure at an air filter may not be greater than 50 mbar. The air filters are changed once a year, but when there is such a great loss in pressure, the air filter is made dirty and sometimes has to be exchanged earlier.

1. Each time 50 mbar is exceeded, the SCADA system transfers this in the form of a measurement reading (for example, 52 mbar) via the PM-PCS interface to the R/3 System.
2. The R/3 System generates a measurement document for the measurement reading of 52 mbar.
3. The R/3 System recognizes 53 mbar as a measurement that exceeds the threshold value of 50 mbar, or as the valuation code "Measurement reading not OK".
4. The R/3 System generates a malfunction notification and, where appropriate, an order via the customer exit IMRC0001.

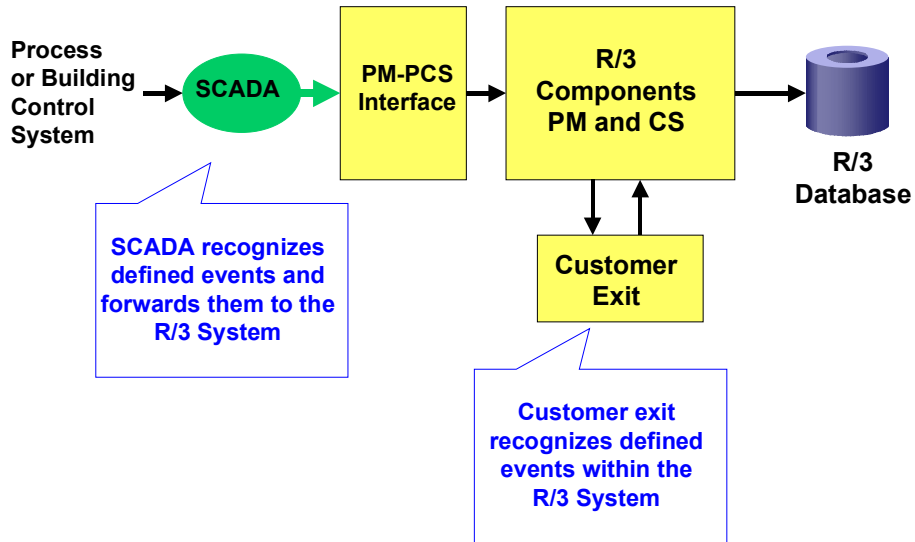

For more information on the maintenance planning functions in the R/3 System (for example, creating a maintenance plan, performing scheduling) see [Maintenance Planning \[Ext.\]](#).

---

**Customer Exit IMRC0001**

## Customer Exit IMRC0001

### Use

You can use this customer exit and the function modules behind it to:

- Define particular field contents in measuring points, counters and measurement documents
- Define and trigger automated business processes
- Update customer-specific tables

### Features

You have the following options for automating business processes with the customer exit IMRC0001:

- Condition-based maintenance
- Scheduling maintenance plans
- Internal cost assignment

### Condition-Based Maintenance

The system automatically triggers a malfunction notification when particular threshold values are exceeded, or if particular valuation codes occur.

You can define measurement range limits, meaning a value range in which the measurement results may lie, for each technical object. In *Customizing for Measuring Points, Counters and Measurement Documents*, you can configure the settings so that the system issues a warning or an error message in the event of the measurement exceeding the measurement range.

You can also define that a malfunction notification is triggered when measurement readings exceed a particular threshold value. Customer exits can be used in the notification to trigger further tasks, such as the creation of an order.

The **valuation code** is a standardized code for valuating the measurement reading, and is specified in addition to the measurement reading. For example, measurement reading *100 degrees Celsius* with valuation code *0001* (which means *“Measurement OK”*), measurement reading *105 degrees Celsius* with the valuation code *“Measurement reading not OK”*.

In certain cases, it is sufficient to specify a valuation code (for example, *1000 “Fire door OK”*, *1001 “Fire door damaged”*, *2001 “Fire door: no local alarm”*, *2002 “Fire door: no alarm in central control office”*).

In the case of valuation codes that you have defined, the system can automatically trigger a malfunction notification that already contains the text of the valuation code as the malfunction description.

### Scheduling Maintenance Plans

The system can schedule maintenance plans automatically. Scheduling is started each time a measurement document is saved. It makes sense to use this customer exit if you have a large number of maintenance plans, but only a few measurement and counter readings.

## Internal Cost Assignment

You can use this customer exit to perform consumption billing (for example, for electricity, gas, water) in the form of internal cost assignment. This would mean, for example, that the heating costs for a technical system are passed on to the appropriate production cost center, or the water costs for a block of flats are passed on to the individual tenants.

For example, you can assign a meter for heating costs to a technical system that you represent in the R/3 System as a [functional location \[Ext.\]](#). You enter the cost center of the functional location in the master record of this functional location. You then define the events to be passed on using customer-specific fields. For example, the system can pass on the heating costs each time 1000 heating units are used.

## Activities

To call up the online documentation for the customer exit and for the function module, proceed as described in [Calling up Documentation for the Exit \[Page 20\]](#).

---

**Calling up Documentation for the Exit**

## Calling up Documentation for the Exit

### Calling up Documentation for the Customer Exit IMRC0001

1. Choose *Tools* → *ABAP Workbench*.
2. Then choose *Utilities* → *Enhancements* → *Project management*.
3. Enter **IMRC0001** and select *Documentation* as the object component.
4. Choose *Display* and the online documentation is displayed.

### Calling up Documentation for the Function Module EXIT\_SAPLIMR0\_001

1. Choose *Tools* → *ABAP Workbench*.
2. Then choose *Development* → *Function Builder*.
3. Enter **EXIT\_SAPLIMR0\_001** and select *Interface* as the object component.
4. Choose *Display*.
5. Choose *Goto* → *Further options* → *Documentation* → *Function module doc.* and the online documentation is displayed.

## Entering Measurement and Counter Readings

### Use

You have five different options for entering measurement and counter readings in the R/3 System.

### Overview of all Options for Entering Measurement and Counter Readings

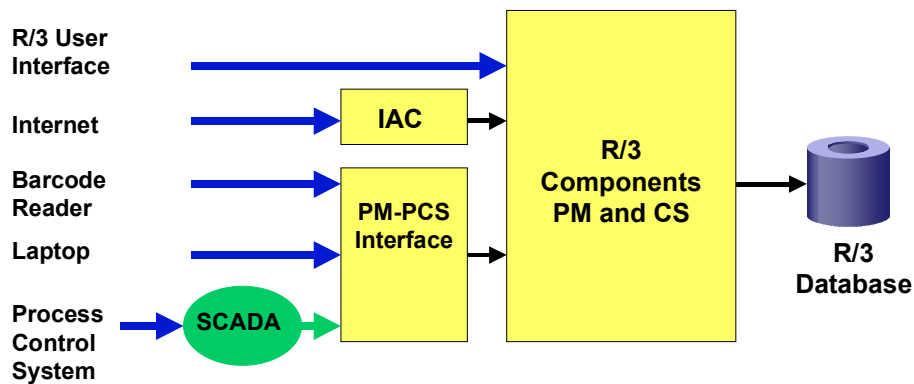

The PM-PCS Interface is an interface between the R/3 System and external systems, such as a Process Control System (PCS). Data from a process control system is data that arises during the monitoring, control, regulation, and optimization of a technical process. You can transfer this data to the R/3 System via the PM-PCS Interface. When transferring data, you can use a SCADA System (Supervisory Control and Data Acquisition System) which filters the data from the process control system and only transfers the data that is actually relevant to the R/3 System.

### Features

Option for Entering Measurement and Counter Readings	Transfer into the R/3 System	For more information, see:

**Entering Measurement and Counter Readings**

R/3 User Interface	No transfer, because data is created directly in the R/3 System.	<a href="#">Creating a Measurement Document [Page 39]</a>
Internet Application Components	The data is transferred via the Internet into the R/3 System.	<a href="#">Entering Measurement and Counter Readings in the Internet [Ext.]</a>
Barcode Reader	The data is transferred via the PM-PCS Interface into the R/3 System.	<a href="#">Entering Measurement and Counter Readings As Barcodes [Page 23]</a> <a href="#">PM-PCS Interface [Ext.]</a>
Laptop	The data is transferred via the PM-PCS Interface into the R/3 System.	<a href="#">PM-PCS Interface [Ext.]</a>
Process Control System with SCADA system (Supervisory Control And Data Acquisition system)	The data is transferred via the PM-PCS Interface into the R/3 System.	<a href="#">PM-PCS Interface [Ext.]</a>

## Entering Measurement and Counter Readings as Barcodes

### Purpose

You use barcode readers for entering measurement and counter readings if:

- You have to take a large number of readings
- You have to enter barcode IDs of ten or more digits
- You require a robust device for entering data

The following scenarios illustrate the use of barcode readers.

### Scenario 1: Barcode ID and Valuation Code are Scanned

You have represented a building in the R/3 System using a hierarchy of functional locations, including the fire doors. Each fire door is assigned a measuring point that is represented by a barcode ID. Once a month, each individual fire door is checked. Most of the time, the result of inspection is "Door is OK", but this inspection result should also be documented in the R/3 System.

The possible defects can be represented clearly using valuation codes. The valuation code is also entered in barcode form. Defects that are determined during the inspection must trigger the creation of a malfunction notification in the R/3 System.

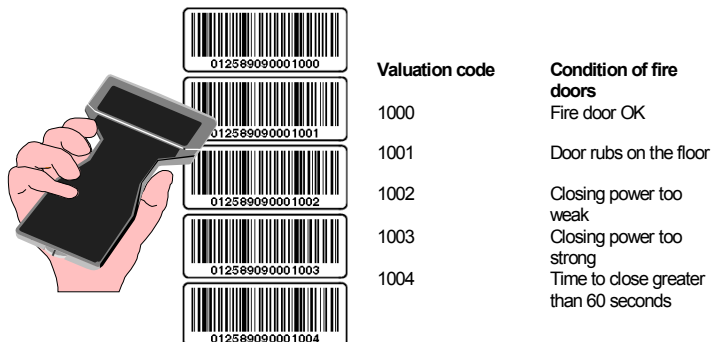

## Entering Measurement and Counter Readings as Barcodes

### Scenario 2: Barcode ID is Scanned, Counter Reading is Entered Manually

You have represented a block of flats in the R/3 System using a hierarchy of functional locations. Each flat is assigned an electricity meter that is represented by a barcode ID. The electricity meter is read once a year.

The meter reading cannot be entered as a barcode, but is instead entered manually by the meter reader using a key pad on the barcode reader. Consumption billing is performed in the industry-specific component *Real Estate Management* (RE) on the basis of the meter readings that are entered in the R/3 System.

### Prerequisites

You need a barcode reader device with the appropriate transfer programs.

To be able to transfer the data from the barcode reader to the R/3 System, use the [PM-PCS Interface \[Ext.\]](#). If you want to create automatically malfunction notifications for the measurement document, use the [customer exit IMRC0001 \[Page 18\]](#).

If you want to print out barcodes from the R/3 System using SAPscript, you can find out about the prerequisites for doing this in the Online Service System note 5196.

### Process Flow

1. You compile a list of the measuring points and counters in the sequence that they will be read in preparation for this to be done. This list is represented in the R/3 System as a [measurement reading entry list \[Page 54\]](#).
2. The person taking the readings first scans the barcode ID for each measuring point and counter with a barcode reader.
3. In Scenario 1, the person taking the readings scans one of the valuation codes that is on their list.  
In Scenario 2, the person taking the readings enters the counter reading manually.
4. After all the measurement and counter readings have been taken, you transfer the data from the barcode reader via infra-red to the docking station. The barcode reader supplies the data that is transferred to the R/3 System via the PM-PCS Interface.
5. The R/3 System generates a measurement document for each measurement and counter reading.
6. If you are using the customer exit IMRC0001, the system generates a malfunction notification in Scenario 1 for each measurement document that has one of the valuation codes predefined by you.

In Scenario 2, the measurement document forms the basis on which consumption billing is performed in the industry-specific component *Real Estate Management*.

Entering Measurement and Counter Readings as Barcodes

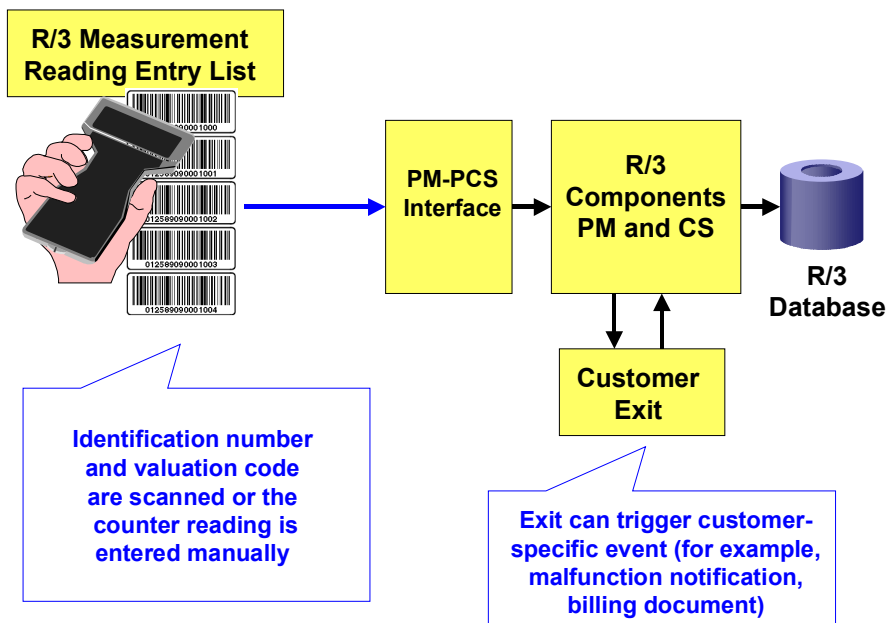

## Basic Functions

# Basic Functions

## Use

These functions are obligatory if you are using measuring points, counters and measurement documents in the R/3 System. You use them in the R/3 user interface to create master records for measuring points and counters, to process the master records and to create measurement documents for them.

Even if you do not enter measurement and counter readings via the R/3 user interface, but instead automatically or semi-automatically (for example, via a process control system or barcode) you must still first create the master records for the measuring points and counters.

## Features

The following functions are basic functions:

- [Creating Measuring Points and Counters \[Page 27\]](#)

You create the master records for measuring points and counters and assign them to a technical object. This can be a piece of equipment or a functional location.

- [Processing Measuring Points and Counters \[Page 37\]](#)

If you want to make changes in the master record of a measuring point or counter, you can either call up this master record directly, or from the master record of the technical object that is assigned to it.

- [Creating Measurement Documents \[Page 39\]](#)

- [Processing Measurement Documents \[Page 41\]](#)

Measurement and counter readings are represented in the R/3 System as measurement documents. You can create measurement documents for the following objects:

- For a technical object (for example, in the case of routine readings and measurements)
- For several measuring points and counters simultaneously
- For several technical objects simultaneously
- For a notification
- For an order (using the technical completion confirmation)

## Creating Measuring Points and Counters

### Prerequisites

#### Definition of Measuring Point Categories

Before you can create measuring points and counters in the system, you must first define the measuring point categories that are valid for your system using the Customizing function.

#### Creating Characteristics

Next, you must ensure that the characteristics that you want to assign to the measuring points and counters, were created using the classification system. You can access characteristics within the framework of measuring point and counter processing, using the following menu paths:

- *Logistics* → *Plant maintenance* → *Technical objects* → *<Technical object>* → *<Processing mode>* → *Extras* → *Measuring points/counters* → *Environment* → *Characteristics* → *<Processing mode>*
- *Logistics* → *Plant maintenance* → *Technical objects* → *Environment* → *Measuring points* → *<Processing mode>* → *Environment* → *Characteristics* → *<Processing mode>*

For more information on how to process characteristics, see the SAP documentation *MM - Characteristics*.

#### Creating Code Groups

If you want to qualitatively evaluate measurement and counter readings, the code groups you specify in the master records of measuring points and counters for this purpose must have been created in the system.

For more information on how to process code groups, see the SAP documentation *PM - Maintenance Notifications*.

### Process Flow

	<b>Creating a measuring point/counter when processing a technical object</b>	<b>Creating a measuring point/counter directly</b>
1.	You call up the master record of the technical object from the screen <i>Maintain Measuring Points: Overview</i> .	You call up the initial screen directly.
2.	If you want to create a counter, you select the field <i>MeasPoint is counter</i> .	
3.	You enter data as required in the overview screen.	You make reference to a technical object in the initial screen.

**Creating Measuring Points and Counters**

4.	The system assigns a number for the measuring point or counter.
5.	You enter data as required in the detail data screen.

## Creating Measuring Points When Processing a Technical Object

1. In the create or change mode, call up the technical object that you want to create measuring points for.

For more information on how to create or change a technical object, see the documentation *PM - Structuring Technical Systems*.

2. Call up one of the master record screens of the technical object.
3. Choose *Extras* → *Measuring points/counters*.

The overview screen for maintaining measuring points and counters for the object is displayed.

4. For each measuring point that you want to assign to the technical object, fill out the two lines provided with the necessary data.



Bear in mind the following rules:

If you want to enter quantitative measurement results for the measuring point (for example, 20 degrees Celsius, 10 cm, 300 ampere, 1000 candela), you must assign a numerical characteristic to it with the required unit.

If you want to enter qualitative measurement results for the measuring point (for example, sufficient, low, too high, too dry), you must assign the required code group to it.

If the entry of qualitative measurement results in the form of an evaluation code is sufficient for a measuring point, you do not need to enter any characteristics for the measuring point. You just specify a code group and later select the field *ValCode sufficient* in the detail screen with the general data for the measuring point.

If you want, you can assign both a characteristic and a code group to a measuring point.

5. After you have made all the necessary entries, choose *Continue*.

The system then assigns a number from an internal number range to each measuring point.

If you have already entered the measurement position for each measuring point, the system sorts the measuring points according to entries in the field *MeasPosition*.

6. For further processing of the measuring points, you must switch to individual processing for each measuring point.

To do this, select the measuring point that you want to process, and choose *Goto* → *MeasPoint*.

This brings you to the detail screen for the measuring point, where you can maintain its general data.

7. Enter data as required.

---

**Creating Measuring Points When Processing a Technical Object**

If the entry of qualitative measurement results is sufficient for a measuring point, and you have therefore only entered a code group (no characteristic) for it, select the field *ValCode sufficient*.

Make any other necessary entries. For more information on this, see the detailed descriptions in the following topics:

- [Defining a Measurement Range \[Page 36\]](#)
  - [Defining Data for a Measurement/Counter Reading Transfer \[Page 50\]](#)
  - [Classifying a Measuring Point/Counter \[Page 35\]](#)
8. Return to the master record screen of the technical object, from which you called up measuring point processing.
  9. Save the master record.

## Creating a Measuring Point Directly

1. From the initial R/3 menu, choose *Logistics* → *Plant maintenance* → *Technical objects* → *Environment* → *Measuring points* → *Create*.

The initial screen for the direct maintenance of measuring points is displayed.

2. Specify in the field *MeasPointObject*, whether the measuring point that you want to create is located at a functional location or at a piece of equipment.
3. Choose *Continue*.
4. Enter the number of the technical object that you wish to create the measuring point for, and the required measuring point category.
5. Choose *Continue*. The detail screen for maintaining general data for the measuring point is displayed.
6. Enter data as required in the detail screen.



Bear in mind the following rules:

If you want to enter quantitative measurement results for the measuring point (for example, 20 degrees Celsius, 10 cm, 300 ampere, 1000 candela), you must assign a numerical characteristic to it with the required unit.

If you want to enter qualitative measurement results for the measuring point (for example, sufficient, low, too high, too dry), you must assign the required code group to it.

If the entry of qualitative measurement results in the form of an evaluation code is sufficient for a measuring point, you do not need to enter any characteristics for the measuring point. You just specify one code group and select the field *ValCode sufficient*.

If you want, you can assign both a characteristic and a code group to a measuring point.

Make any other necessary entries. For more information on this, see the detailed descriptions in the following topics:

- [Defining a Measurement Range \[Page 36\]](#)
- [Defining Data for a Measurement/Counter Reading Transfer \[Page 50\]](#)
- [Classifying a Measuring Point/Counter \[Page 35\]](#)

7. Save the master record of the measuring point.

## Creating Counters When Processing a Technical Object

## Creating Counters When Processing a Technical Object



From the point of view of technical data, a counter represents a particular type of measuring point (see also [Counter \[Page 11\]](#)).

1. In create or change mode, call up the technical object that you want to create counters for.  
For more information on how to create or change a technical object, see the documentation *PM - Structuring Technical Systems*.
2. Call up one of the master record screens of the technical object.
3. Choose *Extras* → *Measuring points/counters*.  
The overview screen for maintaining measuring points and counters for the object is displayed.
4. For each counter that you want to assign to the technical object, fill out the two lines provided with the necessary data.
5. After you have made all the necessary entries, choose *Continue*.  
The system then assigns a number from an internal number range to each counter in the field *Measuring point*.  
If you have already entered the measurement position for each counter, the system sorts the counters according to entries in the field *MeasPosition*.
6. For further processing of the counters, you must change to individual processing for each counter.  
To do this, select the counter that you want to process, and choose *Goto* → *MeasPoint*.  
This brings you to the detail screen for the counter, where you can maintain its general data.
7. In the *General data* block, select the field *MeasPoint is counter*. This designates the measuring point as a counter, which is of importance when entering further data.
8. Choose *Continue* and enter data as required. For more information on this, see the detailed descriptions in the following topics:
  - [Defining a Measurement Range \[Page 36\]](#)
  - [Defining Data for a Measurement/Counter Reading Transfer \[Page 50\]](#)
  - [Classifying a Measuring Point/Counter \[Page 35\]](#)

Counter data can be entered in the fields in the lower half of the screen. If the counter is to be used for scheduling maintenance plans, you must make an entry in the field *AnnualEstimate*.

If you want to enter an initial total counter reading for a counter, to act as the basis for all further readings, proceed as described in [Setting the Total Counter Reading Externally \[Page 55\]](#).

---

**Creating Counters When Processing a Technical Object**

9. Return to the master record screen of the technical object, from which you called up measuring point processing.
10. Save the master record.

## Creating a Counter Directly

## Creating a Counter Directly



From the point of view of technical data, a counter represents a particular type of measuring point (see also [Counter \[Page 11\]](#)).

1. From the initial R/3 menu, choose *Logistics* → *Plant maintenance* → *Technical objects* → *Environment* → *Measuring points* → *Create*.

The initial screen for the direct maintenance of measuring points and counters is displayed.

2. Specify in the field *MeasPointObject*, whether the measuring point that you want to create is located at a functional location or at a piece of equipment.
3. Choose *Continue*.
4. Enter the number of the technical object that you want to create the measuring point for, and the required measuring point category.
5. Select the checkbox *MeasPoint is counter*. This is of importance when entering further data in the detail screen.
6. Choose *Continue*.

The detail screen for maintaining general data for the counter is displayed.

7. Make any other necessary entries. For more information on this, see the detailed descriptions in the following topics:
  - [Defining a Measurement Range \[Page 36\]](#)
  - [Defining Data for a Measurement/Counter Reading Transfer \[Page 50\]](#)
  - [Classifying a Measuring Point/Counter](#)

[\[Page 35\]](#) Counter data can be entered in the fields in the lower half of the screen. If the counter is to be used for scheduling maintenance plans, you must make an entry in the field *AnnualEstimate*.

If you want to enter an initial total counter reading for a counter, to act as the basis for all further readings, proceed as described in [Setting the Total Counter Reading Externally \[Page 55\]](#).

8. Save the master record of the counter.

## Classifying a Measuring Point/Counter

1. In the detail data screen of the measuring point or counter in which you maintain general data, choose *Goto* → *Classification*.

A list entry screen is displayed, in which you can enter the required classes.



You can only enter classes of a class type that allows the assignment of measuring points and counters.

2. If necessary, maintain the characteristic valuations for the classes entered. To do this, position the cursor on the class required and choose *Edit* → *Values*.

This brings you to the characteristic valuation assignment screen for the respective class.

Enter the values for the entered characteristics, and return to the list entry screen for classes of the measuring point or counter.

3. Flag one of the listed classes as the standard class.
4. Return to the detail screen for the general entries regarding the measuring point/counter.

For more information on the classification system, see the SAP documentation *MM Classification System*.

## Defining a Measurement Range

# Defining a Measurement Range

## Use

### Example of a Measuring Point:

A storeroom for fruit is represented in the system as functional location SR1-FR2. The temperature in this room is checked continuously by a measuring device (thermometer). A measuring point has been created for this in the system for functional location SR1-FR2.

The thermometer that checks the temperature can display temperatures in the range +40 C (upper measurement range limit) and -20 C (lower measurement range limit). The unit "degrees Celsius" belongs to the dimension "temperature", like the unit of the characteristic assigned to the measuring point.

### Example of a Counter:

The milometer of a vehicle can display values in the range 0 to 99,999. Since vehicles of this category have an expected life of 200,000 miles as general rule, a counter overflow will occur several times before this total counter reading is reached. The employee responsible will enter a measurement range of 0 to 200,000 for the milometer.

## Procedure

1. In the detail data screen of the measuring point or counter where you maintain general data, choose *Goto* → *Additional data...*

A dialog box for additional data is displayed for the measuring point or counter.

In the upper half of the dialog box there are input fields for the measurement range limits.

2. Enter the upper and lower measurement range limits and the measurement range unit.



The measurement range unit must have the same dimension as the unit of the characteristic that you assigned to the measuring point or counter.

For counters, the measurement range limits do not apply to the counter reading that is read, but to the total counter reading determined by the system.

3. Choose *Continue*.

You return to the detail screen for the general data for the measuring point or counter.

## Processing Measuring Points and Counters

To call up the individual functions in the table, choose *Logistics* → *Plant maintenance* → *Technical objects*.

Function	Menu path	What you should know
Changing a measuring point or counter when processing a technical object	<i>FunctLocation</i> → <i>Change</i> or <i>Equipment</i> → <i>Change</i> , and then in a master data screen <i>Extras</i> → <i>Measuring points/counters</i>	You can change the detail data for any selected measuring point or counter by choosing <i>Goto</i> → <i>MeasPoint</i> .
Changing a measuring point or counter directly	<i>Environment</i> → <i>Measuring points</i> → <i>Change</i>	
Changing measuring points or counters using list editing	<i>Environment</i> → <i>Measuring points</i> → <i>Change</i>	You use this function if you want to change several measuring points or counters that are not assigned to the same technical object.  For more information, see <a href="#">Working With Lists [Ext.]</a> .
Changing the measuring point category	<i>Environment</i> → <i>Measuring points</i> → <i>Change</i> , and then in the general data screen for the measuring point <i>Edit</i> → <i>Change MeasPoint category</i>	You use this function if you want to assign an existing measuring point or counter to another measuring point or counter.
Deactivating a measuring point or counter	<i>Environment</i> → <i>Measuring points</i> → <i>Change</i> , and then in the general data screen for the measuring point <i>MeasPoint</i> → <i>Functions</i> → <i>Active &lt;-&gt; Inactive</i> → <i>Deactivate</i>	You use this function if you do not want to delete a measuring point or counter, but want to prevent further measurement documents being created for it.
Activating a measuring point or counter	<i>Environment</i> → <i>Measuring points</i> → <i>Change</i> , and then in the general data screen for the measuring point <i>MeasPoint</i> → <i>Functions</i> → <i>Active &lt;-&gt; Inactive</i> → <i>Activate</i>	You use this function to reverse a deactivation.
Displaying a measuring point or counter from the technical object	<i>FunctLocation</i> → <i>Display</i> or <i>Equipment</i> → <i>Display</i> , and then in a master data screen <i>Extras</i> → <i>Measuring points/counters</i>	You can display the detail data for any selected measuring point or counter by choosing <i>Goto</i> → <i>MeasPoint</i> .

## Processing Measuring Points and Counters

Displaying a measuring point or counter directly	<i>Environment → Measuring points → Display</i>	
Displaying a measuring point or counter using list editing	<i>Environment → Measuring points → List editing → Display</i>	You use this function if you want to display several measuring points or counters that are not assigned to the same technical object.  For more information, see <a href="#">Working With Lists [Ext.]</a> .
Deleting a measuring point or counter	<i>FunctLocation → Change or Equipment → Change, and then in a master record screen Extras → Measuring points/counters and then in the overview screen Edit → Delete entries</i>	You can only delete measuring points or counters for which no measurement documents have yet been entered.

## Creating Measurement Documents

### Prerequisites

Please note the following rules when creating a measurement document for a **measuring point**:

You can only enter a valuation code on its own when the indicator *ValCode sufficient* has been set in the master record of the measuring point.

Please note the following rules when creating a measurement document for a **counter**:

Enter either the counter reading, or the difference between the current reading and the last reading. The system will automatically calculate the other value in each case.

### Procedure

To call up the individual functions in the table, choose *Logistics → Plant maintenance → Technical objects*.

Function	Menu path	What you should know
Creating a measurement document directly	<FunctLocation/Equipment> → Measurement documents → Create	You use this function for routine readings and measurements.
Creating measurement documents for several measuring points or counters simultaneously	<FunctLocation/Equipment> → Measurement documents → List editing → Create	You use this function if you want to create measurement documents for several measuring points or counters of a <b>single</b> technical object.  You can change the detail data for any selected measuring point or counter by choosing <i>Goto → MeasPoint</i> .
Creating measurement documents for several technical objects simultaneously	<i>Logistics → Plant maintenance → Maintenance processing → Completion confirmation → Measurement documents → Multiple entry → For MeasPointObjects</i>	You use this function if you want to create measurement documents for several measuring points or counters of <b>different</b> technical objects.  You can change the detail data for any selected measuring point or counter by choosing <i>Goto → MeasPoint</i> .
Creating a measurement document for a maintenance notification	<i>Logistics → Plant maintenance → Maintenance processing → Notifications → &lt;Required processing mode&gt;</i>	You can change the detail data for any selected measuring point or counter by choosing <i>Goto → MeasPoint</i> .

**Creating Measurement Documents**

Creating a measurement document for a maintenance order		To call up this function, use the technical completion confirmation. You access the corresponding activity report from the order (See <a href="#">The Central Completion Confirmation Function [Ext.]</a> ).
Creating a measurement document during order completion confirmation		To be able to create a measurement document for an order operation, first create an operation list for the order, then select the required operation and create the measurement document for it (See <a href="#">The Central Completion Confirmation Function [Ext.]</a> ).

## Processing Measurement Documents

To call up the individual functions in the table, choose *Logistics* → *Plant maintenance* → *Technical objects*.

Function	Menu path	What you should know
Changing a measurement document	<ul style="list-style-type: none"> <li>• &lt;FunctLocation/Equipment&gt; → <i>Measurement documents</i> → <i>Change</i></li> <li>• <i>Logistics</i> → <i>Plant maintenance</i> → <i>Maintenance processing</i> → <i>Completion confirmation</i> → <i>Measurement documents</i> → <i>Change</i></li> </ul>	You can use these functions to change the text for the measurement document and the processing status.
Changing measurement documents using list editing	<ul style="list-style-type: none"> <li>• &lt;FunctLocation/Equipment&gt; → <i>Measurement documents</i> → <i>List editing</i> → <i>Change</i></li> <li>• <i>Logistics</i> → <i>Plant maintenance</i> → <i>Maintenance processing</i> → <i>Completion confirmation</i> → <i>Measurement documents</i> → <i>List editing</i> → <i>Change</i></li> </ul>	You can use these functions to change the text for the measurement document and the processing status.
Displaying a measurement document	<ul style="list-style-type: none"> <li>• &lt;FunctLocation/Equipment&gt; → <i>Measurement documents</i> → <i>Display</i></li> <li>• <i>Logistics</i> → <i>Plant maintenance</i> → <i>Maintenance processing</i> → <i>Completion confirmation</i> → <i>Measurement documents</i> → <i>Display</i></li> </ul>	<p>If you want to check values, you can display the original entries for the measurement document by calling up the screen <i>General Data</i> for the measurement document, and then choosing <i>Extras</i> → <i>Original entries</i>.</p> <p>If you want to check changes, you can display a list of all change documents for the measurement document by calling up the screen <i>General Data</i> for the measurement document, and then choosing <i>Extras</i> → <i>Display changes</i>. You access the detail data for the change document by choosing <i>Goto</i> → <i>Display documents</i>.</p>

Processing Measurement Documents

<p>Displaying measurement documents using list editing</p>	<ul style="list-style-type: none"> <li>• &lt;FunctLocation/Equipment&gt; → Measurement documents → List editing → Display</li> <li>• Logistics → Plant maintenance → Maintenance processing → Completion confirmation → Measurement documents → List editing → Display</li> </ul>	
<p>Reversing a measurement document</p>	<ul style="list-style-type: none"> <li>• &lt;FunctLocation/Equipment&gt; → Measurement documents → Change</li> <li>• Logistics → Plant maintenance → Maintenance processing → Completion confirmation → Measurement documents → Change</li> </ul> <p><b>and then</b> in the screen <i>General Data</i> of the measurement document, choose <i>MeasDocument</i> → <i>Functions</i> → <i>Reversal indicator</i> → <i>Set</i>.</p>	<p>When you reverse a measurement document, the system sets the appropriate indicator in the measurement document concerned.</p> <p>If you reverse a measurement document within a sequence of consecutive measurement documents, the system recalculates the resulting value (<a href="#">Example [Page 44]</a>).</p>
<p>Resetting the reversal indicator for a measurement document</p>	<ul style="list-style-type: none"> <li>• &lt;FunctLocation/Equipment&gt; → Measurement documents → Change</li> <li>• Logistics → Plant maintenance → Maintenance processing → Completion confirmation → Measurement documents → Change</li> </ul> <p><b>and then</b> in the screen <i>General Data</i> of the measurement document, choose <i>MeasDocument</i> → <i>Functions</i> → <i>Reversal indicator</i> → <i>Reset</i>.</p>	<p>If you reset the reversal indicator for a measurement document within a sequence of consecutive measurement documents, the system recalculates the resulting value (<a href="#">Example [Page 44]</a>).</p>

Processing Measurement Documents

<p>Processing the measurement document for the measuring point or counter when processing the measurement point or counter</p>	<p>In the screen <i>General Data</i> for the measuring point or counter, choose <i>Extras</i> → <i>MeasDoc history</i> → <i>MeasDocument list</i></p>	<p>In the measurement document list you have the option of calling up a graphical display of the measurement documents by choosing <i>Goto</i> → <i>MeasDoc graphic</i>.</p>
<p>Displaying an archived measurement document</p>	<p>&lt;<i>FunctLocation/Equipment</i>&gt; → <i>Measurement documents</i> → <i>List editing</i> → <i>Display archive</i></p>	<p>The system displays a list of all measurement documents that have already been archived as if they were still available in the R/3 System.</p>
<p>Displaying the last measurement document created for a measuring point or counter</p>	<ul style="list-style-type: none"> <li>• In the screen <i>General Data</i> for the measuring point or counter, choose <i>Extras</i> → <i>MeasDoc history</i> → <i>Last MeasDocument</i></li> <li>• In the overview screen for all measuring points or counters for a technical object, select the required measuring points or counters, and choose <i>Extras</i> → <i>MeasDoc history</i> → <i>Last MeasDocument...</i></li> </ul>	
<p>Displaying the last measurement document created for all measuring points or counters of a technical object</p>	<p>In the overview screen for all measuring points or counters for a technical object, choose <i>Extras</i> → <i>MeasDoc history</i> → <i>... for all MeasPoints</i></p>	

## Example for Reversing a Measurement Document

## Example for Reversing a Measurement Document

If you reset the reversal indicator of a measurement document for a counter, the system recalculates the measurement document concerned, as well as all subsequent measurement documents that have already been created. The following rules apply:

- If an absolute counter reading was entered previously, the system will recalculate the counter reading difference and the total counter reading with reference to the previous measurement document.
- If a counter reading difference was entered previously, the system will recalculate the absolute counter reading and the total counter reading with reference to the previous measurement document.

Date	Action	Difference entered	Total counter reading
30.06.1997	Document #1 entered	100	100
15.07.1997	Document #2 entered	100	200
30.07.1997	Document #3 entered	100	300
10.08.1997	Document #2 reversed		
	↓		
	Document #3 recalculated	100	200
11.08.1997	Reversal indicator reset in document #2		
	↓		
	Document #2 recalculated	100	200
	Document #3 recalculated	100	300

## Additional Functions

### Use

You only use these optional functions once you have represented your measuring points and counters in the R/3 System and are productively using the entry of measurement and counter readings.

You use some of these functions just once when a particular event occurs. None of the additional functions constitutes a necessary part of your day-to-day work.

### Features

- [Transfer of Measurement and Counter Readings \[Page 46\]](#)

Dependencies can exist between measuring points/counters. The measurement readings entered for a measuring point can also be valid for other measuring points, or the counter reading differences entered for a counter can also be valid for other counters. In cases such as these, you can make sure that this data is transferred automatically.
- [Working With a Measurement Reading Entry List \[Page 54\]](#)

You can compile a freely definable sequence of measuring points/counters to better plan the actual procedure of entering measurement and counter readings (for example, in preparation for the work to be performed by the person taking the readings).
- [Setting the Total Counter Reading Externally \[Page 55\]](#)
- [Representing Counter Replacement \[Page 56\]](#)

A one-off activity that you only perform when you replace counters.
- [Converting Units of Measurement \[Page 57\]](#)

The R/3 System converts measurement units automatically. You can simulate this conversion function.

Transfer of Measurement and Counter Readings

## Transfer of Measurement and Counter Readings

### Use

This function comprises the following types of transfer:

- Measurement reading transfer from one measuring point to another (1:1 relationship)



The proportion of chlorine in the water of a swimming pool is measured on a regular basis. To do this, water samples are taken from the pool, and the measurement readings determined are entered for the measuring point that has been created in the system for the pool.

A measuring point has also been created for the swimming pool's circulation pump, for which the chlorine content of the water is also relevant. The measurement readings determined for the swimming pool are copied from the measuring point of the pump, since this value also concerns the pump: the greater the concentration of chlorine in the water, the greater the risk of corrosion to the pump.

- Measurement reading transfer from one measuring point to several others (1:n relationship)
  - Counter reading transfer from one counter to another (1:1 relationship)
- Counter reading transfer from one counter to several others (1:n relationship)



A passenger airplane is represented in the system as a functional location. The starts and landings are counted for the airplane, since certain maintenance tasks are dependent on the number of times the airplane takes off and lands.

The tires of the undercarriage are represented on one of the lower levels of the functional location. The tires must be changed after a certain number of starts and landings.

The counter that counts the number of starts and landings for the airplane copies the counter reading difference to the counter that counts the starts and landings for the tires. This might appear as follows:

<b>Airplane counter:</b>	Total counter reading on March 12 2000: 350 starts and landings	New counter reading entered on March 12 2000: 360 starts and landings
		↓ Difference of 10 starts and landings copied ↓
<b>Landing gear counter for tires:</b>	Total counter reading on March 12 2000: 20 starts and landings	New total counter reading on March 12 2000: 30 starts and landings

Transfer of Measurement and Counter Readings

**Prerequisites**

A measurement or counter reading transfer can only be performed under the following circumstances:

- Measurement readings can only be copied from one measuring point to another if both measuring points have the **same characteristic**. Counter readings can only be copied from one counter to another if both counters have the same characteristic.

Each measuring point or counter has a classification characteristic that is valid for all objects. Characteristics are used to enable measuring points or counters to be compared across all objects, so that you can define, for example, whether this involves a kilometer counter for a car or an operating-hours counter for a cooling compressor.

- You can only transfer measurement and counter readings **within an object hierarchy**. Measurement or counter readings cannot be transferred from other object hierarchies.

Within a hierarchy, you can only transfer measurement or counter readings in a straight line from above or from below; you cannot copy them from another branch.

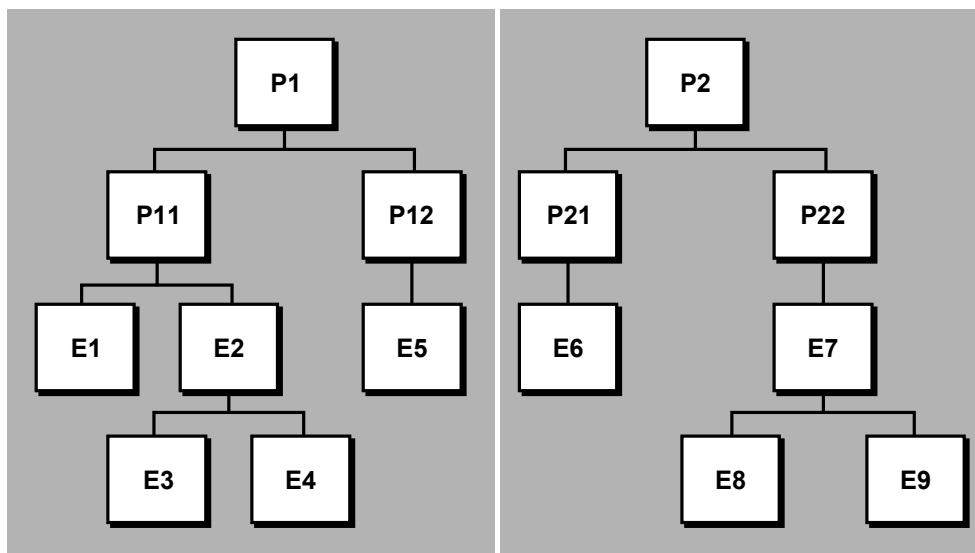

You can only transfer measurement or counter readings within the structure of the functional location P1 and within the structure for the functional location P2. You cannot transfer, for example, the piece of equipment E1 in P1 to the piece of equipment E6 in P2.

You can skip levels within a structure. For example, you can transfer from P11 to E3.

You must transfer measurement or counter readings in a straight line. For example, you can transfer from P1 to E1 or from E4 to P11, however, it is not directly possible to transfer from E1 to E4.

**Special Case:**

A milometer has been mounted on the axle (E2) of a locomotive. The kilometers counted there are to be distributed between the entire axle and wheel sets of the train. However,

## Transfer of Measurement and Counter Readings

it is not possible to transfer these readings directly, as it would mean transferring them diagonally within the hierarchy.

Solution:

The kilometers counted are copied to the train P1 (= copying in a straight line from the bottom to the top). The readings are then transferred from the train to the axle sets and, if necessary, to the wheel sets. Axle E2 does not, however, receive the kilometer reading again as the system checks and stops cyclical copying (if E2 was transferred to P1, P1 cannot transfer back to E2).

## Features

Once a piece of equipment is dismantled from a structure, the system automatically interrupts the measurement reading transfer. A system message is displayed, informing you of the number of measurement readings for which the transfer procedure was interrupted. The same applies when you change the assignment of a piece of equipment to its superior piece of equipment or the assignment of a functional location to its superior functional location.

Once a piece of equipment is dismantled, the indicator *MeasReadTransf. Copying required* remains. When the piece of equipment is installed again, this enables the system to recognize that a measurement reading transfer will probably be necessary. After that, the system checks the object hierarchy (from the installation point upwards) and searches for the measuring points or counters from which a transfer is possible on the basis of the same characteristic. These measuring points or counters are displayed in a proposal list, in which you can define the required measurement reading transfer.



You can also set the indicator *MeasReadTransf. Copying required* as soon as you create the piece of equipment, without having to make an assignment first. When you install the piece of equipment, the system creates the proposal list based on the characteristics that are suited to the equipment. However, the search for suitable measuring points or counters is only performed upwards in the object hierarchy.

This function also comprises the copying of transfer dependencies between measuring points and counters, if you copy functional location structures using the copy reference function.

If a measurement document is entered for an historical reference time, the transfer of the measurement document is performed according to the historical transfer dependencies, even if the object structure has changed in the meantime.

If you have defined transfer dependencies for measuring points and counters, you can display them with respect to time. Depending on the key date, you can display both historical and current transfer dependencies. There are two different display forms:

- As a structure display of all technical objects for which a transfer dependency exists. The technical object with the measuring point or counter from which you called up the report is highlighted.
- As a list display of the historical and current transfer dependencies for a measuring point or counter.



## Defining Data for a Measurement/Counter Reading Transfer

## Defining Data for a Measurement/Counter Reading Transfer

1. In the detail data screen of the measuring point or counter where you maintain general data, choose *Goto* → *Additional data...*

A dialog box for additional data is displayed for the measuring point or counter.

In the lower half of the dialog box, you see the input fields for the transfer of measurement and counter readings.

2. Enter the number of the measuring point or counter, from which the data should be copied.



The characteristic of the measuring point or counter, at which the measurement or counter reading was entered, must correspond to the characteristic of the receiving measuring point or counter. If it does not, then the transfer is not possible.

When transferring measurement readings, the respective value entered for the given measuring point is copied.

When transferring counter readings, the counter reading difference entered or calculated for the given counter is copied.

3. Choose *Continue*.

You return to the detail screen for the general data for the measuring point or counter.

The transfer of measurement or counter readings is usually performed automatically. In the event of the master record for the measuring point or counter being blocked by another user at the time of the transfer procedure, you must [repeat the transfer \[Page 51\]](#).

## Repeating a Measurement or Counter Reading Transfer

### Use

The transfer of measurement or counter readings is usually performed automatically. In the event of the master record for the measuring point or counter being blocked by another user at the time of the transfer procedure, you must repeat the transfer.

### Procedure

1. In the screen *Technical Objects* choose *Environment* → *Measuring points* → *Display or* → *Change*.

The initial screen is displayed.

2. Enter the key of the measuring point or counter that you want to repeat the data transfer for, and choose *Continue*.

3. In the screen *General Data* choose *Environment* → *Take up MR copy funct*.

The system displays a list of all measurement or counter readings for the entire client, for which the data transfer has to be repeated. From this list, you can choose *Goto* → *Display object* to display the data of the original documents and that of the corresponding measuring point or counter.

4. Start the data transfer for each document by positioning the cursor on the respective document line and choose *Edit* → *Take up copy function*.

### Result

The data transfer is repeated for each measurement document using this method. The system informs you in each case whether subsequent measurement documents are available and if they need to be recalculated. If recalculations are necessary, the system informs you of the numbers of changed documents.

## Defining a Measurement/Counter Reading Transfer for Copied Location Structures

## Defining a Measurement/Counter Reading Transfer for Copied Location Structures

### Use

You copy functional location structures using the copy reference function. In the reference, measuring points or counters are created and measurement and counter reading transfers that you want to copy at the same time are defined.

### Procedure

1. Construct the new location hierarchy structure in its entirety.
2. Call up the uppermost functional location in the new hierarchy.  
You have two options for doing this:

In the screen <i>Technical Objects</i> , choose <i>FunctLocation</i> → <i>Change</i> .	In the screen <i>Technical Objects</i> , choose <i>Environment</i> → <i>Measuring points</i> → <i>Object meas.points</i> → <i>Change</i>
Enter the data of the functional location and choose <i>Continue</i> .	Enter the data of the functional location and choose <i>Continue</i> .
Choose <i>Extras</i> → <i>Measuring points/counters</i> .	

The overview screen for measuring points and counters is displayed.

3. In the overview screen, choose *Extras* → *Default MR transfer*.  
The system determines the possible transfer dependencies for measuring points and counters for all subordinate functional locations (including the piece of equipment installed there), and displays this information in list form.
4. Select transfer dependencies as necessary, or accept the system proposals.
5. Save the data of the functional location.

## Displaying the Transfer Hierarchy for a Key Date

### Use



If you have defined transfer dependencies for measuring points and counters, you can display them with respect to time. Depending on the key date, you can display both historical and current transfer dependencies.

If a measurement document is entered for an historical reference time, the transfer of the measurement document is performed according to the historical transfer dependencies, even if the object structure has changed in the meantime.



In an airplane, an average of 2500 pieces of equipment are installed, each with three counters per piece of equipment. One measurement document is created per counter per day and transferred within the defined hierarchy. Sometimes, the case arises where the counter readings are equivalent to planned values that have to be recorded each time the airplane is used, because the actual values are not obtained until some time later. If the actual values that are obtained later deviate from the planned values, they must be updated accordingly. The transfer of these measurement documents that are entered subsequently is performed according to the historical transfer dependencies.

### Displaying the Transfer Structure for a Key Date

1. In the master record of the measuring point or counter, choose *Extras* → *Measurement reading transfer* → ...*Structure*.
2. Enter the required key date. The key date can be either in the present or in the past.
3. Choose *Continue*. The system displays the structure of the measurement reading transfer for the key date that you entered. The technical objects concerned are displayed with their measuring points or counters in the form of an object hierarchy. The measuring point or counter from which you called up the function is highlighted.
4. If you want to change the key date, choose  and enter the new key date.
5. Choose  *Log*, to display the results of the consistency check. Messages that are displayed for the log can also include information about deactivated measuring points or counters.

### Displaying the History from the Perspective of the Measuring Point/Counter

1. In the master record of the measuring point or counter, choose *Extras* → *Measurement reading transfer* → ...*History*.
2. The system displays the transfer dependencies in the form of a time line. This time line usually corresponds to the usage list for the piece of equipment.

---

**Working With a Measurement Reading Entry List**

## Working With a Measurement Reading Entry List

### Use

You use this function to compile a list of measuring points and counters in a freely definable sequence, so that measurement readings can be entered for it (for example, in preparation for the meter reader).

When doing this, the system branches from the measurement reading entry list to the collective entry screen for measurement documents and creates a measurement document for each value.

### Prerequisites

The measuring points and counters must already exist in the system as master records. You cannot create measuring points/counters from the measurement reading entry list.

### Features

You can enter measurement or counter readings directly in the measurement reading entry list, or choose them using the measuring point selection function. You access the measuring point selection screen from the entry list by choosing *Edit* → *Select measuring points*.

### Activities

You access the entry list under the menu path *Logistics* → *Plant maintenance* → *Technical objects* → *Environment* → *Measuring points* → *MeasReading entry list*.

## Setting the Total Counter Reading Externally

### Use

If you want to enter an initial value for a counter, on the basis of which all further counter readings or counter reading differences are to be entered, you can do so using a measurement document.

A total counter reading that is set externally (also known as an "initial document") forms the basis for [counter-based maintenance \[Page 14\]](#).

### Procedure

1. In the screen *General Data* for the measurement document, choose *Edit* → *Replace counter*.  
The *Replace Counter* dialog box is displayed.
2. Select the field *Total CntrReadg set externally*.
3. Choose *Continue*.  
You return to the *General Data* screen. The field *TotalCtrReading* is now ready for input.
4. Enter the required total counter reading and save the data.

## Representing Counter Replacement

## Representing Counter Replacement

### Use

You will need to represent the replacement of a counter in the system if, for example, a counter's mechanism is defective and has to be replaced by another, or if a whole counter unit has to be replaced. In most cases, the counter reading of the old counter will not be the same as that of the new counter, and so an indicator has to be set in a new measurement document to explain the sudden jump in counter readings that have otherwise been increasing or decreasing steadily.



Reading date	Counter reading	Indicator	Total counter reading
17.08.1997	20010		20010
24.08.1997	20100		20100
31.08.1997	20190		20190
04.09.1997	00400	Counter replacement	20190
10.09.1997	00410		20200

When you create a measurement document for documenting the replacement of a counter, the total counter reading does not change. With this measurement document, you enter the new reading that the newly installed counter has at the start of its use. The total counter reading does not change with respect to the last measurement document.

Therefore, if the situation arises in which the reading of the old counter has increased since the last counter reading took place, you should first create a measurement document that records the last counter reading of the old counter. When you have done this, you can then create another measurement document that documents the reading of the newly installed counter at the start of its use. This ensures that all the units counted have been entered in the system.

### Procedure

1. In the screen *General Data* for the measurement document, choose *Edit → Replace counter*.  
The dialog box *Replace Counter* is displayed.
2. Select the field *Counter replaced*.
3. Choose *Continue*.  
You return to the screen *General Data*.
4. Save the data.

## Converting Units of Measurement

### Use

This function helps you to understand the automatic conversion functions of the system. You may use these, for example, when you have a reading for a measurement document in a unit different from the characteristic unit, but want to make the entry in the measurement document in the characteristic unit. This function is also useful if you want to make sense of confusing measurement readings, or display a value in its internal display format (SI unit).

### Features

An SI unit is a unique unit of measurement, that was established for each dimension by the international unitary system (“SI” for the French “système international des unités”).

The following SI units are valid for base dimensions:

Distance:	meter
Mass:	kilogram
Time:	second
Electrical current:	amp
Temperature:	Kelvin
Molar mass:	mole
Brightness:	candela

All other dimensions can be traced back to these base dimensions, for example:

Velocity:	Distance over time
Acceleration:	Change in velocity over time
Force:	Mass multiplied by acceleration
Work:	Force multiplied by distance
Power:	Work over time

### Activities

How do you call up these functions?

If you want to...	...then choose:
Create, change or display a measuring point or counter	In the screen <i>General Data</i> for the measuring point or counter, choose <i>Environment</i> → <i>Convert MeasUnit</i>

**Converting Units of Measurement**

Create, change or display a measurement document	In the screen <i>General Data</i> for the measurement document, choose <i>Environment</i> → <i>Convert MeasUnit</i>
--	---

## Using the Conversion Function

### Using the Function Without Parameterization

1. If you place the cursor on a non-numerical field, it is possible to enter any value. For a numerical field, conversion is performed immediately. Choose *Environment* → *Convert MeasUnit*.

The *Convert Unit of Measurement* dialog box is displayed.

2. Enter the value to be converted together with its unit in the block *Value entry*.
3. In the block *Conversion to target unit*, enter the unit into which the value is to be converted.
4. Choose *Proceed*.

The system enters the value in the block *Conversion to target unit* and shows you in the block *Conversion to SI unit*, in which SI unit it is storing this value, and to which dimension the SI unit belongs.

5. You can now convert further entries. To do this, repeat steps 2 to 4.
6. Save the data.

### Using the Function With Parameterization

1. Place the cursor on the required value, and choose *Environment* → *Convert MeasUnit*.

The *Convert Unit of Measurement* dialog box is displayed. It has already converted the value into the SI unit for the characteristic.

2. In the block *Conversion to target unit*, enter the unit into which the value is to be converted.
3. Choose *Proceed*.

The system calculates the required value and enters in the field in the block *Conversion to target unit*.

4. You can now convert further entries.
5. Save the data.

### Displaying the List of Conversions

1. Choose *Environment* → *Convert MeasUnit*.

The *Convert Unit of Measurement* dialog box is displayed.

2. Select the icon *Conversion list*.

You see a list of all conversions performed in this work operation.