

Library of ALE Business Processes



HELP.CABFAIS

Release 4.6C



Copyright

© Copyright 2001 SAP AG. All rights reserved.

No part of this publication may be reproduced or transmitted in any form or for any purpose without the express permission of SAP AG. The information contained herein may be changed without prior notice.

Some software products marketed by SAP AG and its distributors contain proprietary software components of other software vendors.

Microsoft[®], WINDOWS[®], NT[®], EXCEL[®], Word[®], PowerPoint[®] and SQL Server[®] are registered trademarks of Microsoft Corporation.

IBM[®], DB2[®], OS/2[®], DB2/6000[®], Parallel Sysplex[®], MVS/ESA[®], RS/6000[®], AIX[®], S/390[®], AS/400[®], OS/390[®], and OS/400[®] are registered trademarks of IBM Corporation.

ORACLE[®] is a registered trademark of ORACLE Corporation.

INFORMIX[®]-OnLine for SAP and Informix[®] Dynamic Server[™] are registered trademarks of Informix Software Incorporated.

UNIX[®], X/Open[®], OSF/1[®], and Motif[®] are registered trademarks of the Open Group.





HTML, DHTML, XML, XHTML are trademarks or registered trademarks of W3C[®], World Wide Web Consortium, Massachusetts Institute of Technology.

JAVA[®] is a registered trademark of Sun Microsystems, Inc.

JAVASCRIPT[®] is a registered trademark of Sun Microsystems, Inc., used under license for technology invented and implemented by Netscape.

SAP, SAP Logo, R/2, RIVA, R/3, ABAP, SAP ArchiveLink, SAP Business Workflow, WebFlow, SAP EarlyWatch, BAPI, SAPPHIRE, Management Cockpit, mySAP.com Logo and mySAP.com are trademarks or registered trademarks of SAP AG in Germany and in several other countries all over the world. All other products mentioned are trademarks or registered trademarks of their respective companies.

Icons

Icon	Meaning
	Caution
	Example
	Note
	Recommendation
	Syntax

Inhalt

Library of ALE Business Processes	6
Overview of ALE Integration Scenarios.....	7
Distributable Master Data Objects.....	9
Cross-Application Business Processes	15
Bank Distribution	16
Central User Administration.....	17
Logistics.....	21
Distributing Master Data.....	22
ALE Transfer of Configuration Data.....	23
Work Breakdown Structure or Internal Order Distribution	27
Logistics <-> Logistics	31
Sales and Operations Planning (PP-SOP)	32
Separate Sales and Shipping (SD-SLS, SD-SHP)	36
Stock Transfer Between Distributed Systems (SD, MM)	37
Logistics <-> Human Resources.....	38
Logistics <-> Accounting	39
Human Resources.....	40
Human Resources <-> Human Resources.....	41
Distribution of Trip Costs.....	42
Human Resources <-> Logistics.....	43
Confirmations from PP, PI, PM, CS, and PS	44
Business Event Attendees: Contact Persons	45
Business Event Attendees: Customers.....	47
Business Event Billing.....	49
Material Order in Training and Event Management.....	53
Availability of Employees in Logistics	56
Work Center Integration	57
Qualifications & Requirement Profiles in Logistics.....	58
Assignment of Employees in Logistics.....	59
Daily Work Schedule at Logistics Work Center	60
Human Resources <-> Accounting	61
Posting Payroll Posting Documents.....	62
Wage and Salary Payments.....	65
Activity Allocation in Training and Event Management.....	67
Cost Transfer Posting in Training and Event Management.....	68
Amounts Withheld from Suppliers as Taxes (Spain)	71
Create Vendor Accounts from HR Master Record.....	72
VAT Indicators in HR Travel Customizing.....	73
Human Resources <-> External Applications	74
Process Flow: Import Payroll Results from a Third-Party System	75
Accounting.....	77
Distributing Master Data.....	78
Work Breakdown Structure or Internal Order Distribution	79
Accounting <-> Accounting	83
The Reconciliation Ledger and ALE	84

Financial Accounting (FI-GL)	86
Special Purpose Ledger (FI-SL).....	92
ALE/Distribution in Product Cost Planning.....	93
Distribution to Profitability Analysis and Sales and Distribution.....	96
Group Costing in Distributed Systems.....	98
Further Costing in Other Systems	101
Data Transfer Between Accounting and Logistics Concept (FI/CO-LO)	103
Accounting <-> Human Resources	104
Information systems	105
Logistics Information Systems	106
Inventory Controlling (LO-LIS, MM-INV)	107
Purchasing Information System (MM-IS-PU).....	109
Sales Information System (SD-IS)	111

Library of ALE Business Processes

Purpose

The integration service *Application Link Enabling* (ALE) enables business processes developed across several R/3 Systems or non-SAP systems to be integrated.

Overview of ALE Integration Scenarios

The graphic below shows an overview of ALE integration scenarios. There are a multitude of possible ALE businesses processes for each integration scenario.

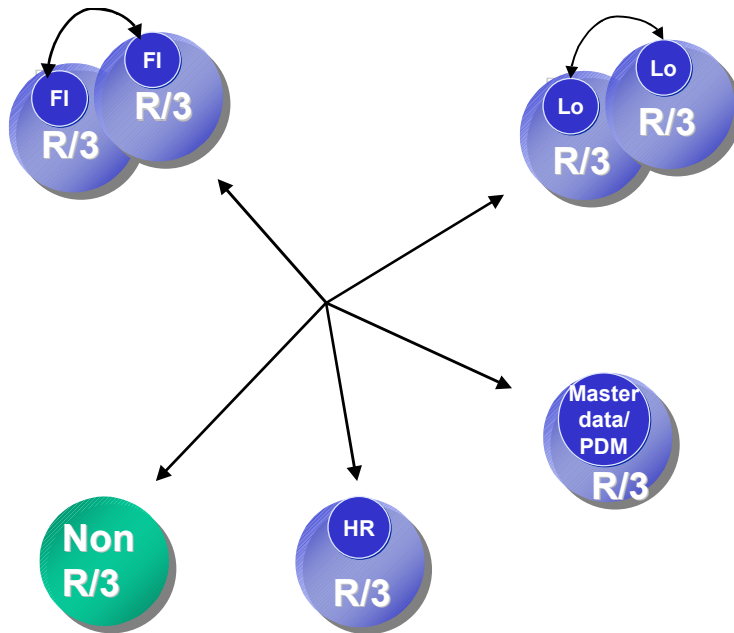

SAP provides a variety of ALE business processes and these are described in this document.

These predefined ALE business processes have been developed for Application Link Enabling and they include important application cases for distributing business functions and processes. They are included in the standard system.

The use of ALE business processes is described in the Implementation Guide for ALE and the Implementation Guide for the relevant applications. This documentation includes links to specific steps in the Implementation Guide.

You can find the ALE Implementation Guide under *Tools* → and *Basis Components* → *Distribution (ALE)*.

The *Interface Adviser* is used to connect to non-SAP systems that do not have predefined business processes. The *Interface Adviser* supports you with the design and implementation of permanent interfaces between R/3 components and external components. You can download the *Interface Adviser* from SAPNet (<http://sapnet.sap-ag.de/int-adviser>).

For further information on ALE see the following documentation:

- [ALE Quick Start \[Extern\]](#)
- [ALE Introduction and Administration \[Extern\]](#)

Overview of ALE Integration Scenarios

- [ALE Programming Guide \[Extern\]](#)

Distributable Master Data Objects

The following master data objects can be distributed:

- Change Numbers
- Article Master Record
- User Master Record
- Purchasing Info Record
- Business Process
- Classification, class and characteristics
- Conditions
- Cost Center
- Cost center group
- Cost element group
- Cost element
- Customer Master Record
- Activity type
- Activity Master Record
- Activity type group
- Vendor Master Record
- Material Master Record
- Unit of measure for cost center and cost element combination
- Source List
- Human Resources: HR Master Data, Organizational Data
- Profit Center
- G/L Account
- Bill of material (materials and documents)
- Activity price of cost center and cost element combination
- Value scale and quota scale

Some of these master data objects are described in more detail below:

Change Numbers

If a change number is distributed using the message type ECMMAS, it contains:

- Change master record (in long text if available)
- Alternative dates

Distributable Master Data Objects

- Validity
- Object types for change master record
- Object management records (in long text if available)

If the distributed change number does not already exist in the target system, it is created here. It is not yet possible to delete a change number in the target system nor to distribute it using a change pointer.

Article Master Record

For further information about distributing articles refer to the topic below in the document *ISR - SAP Retail*:

[Article: Transferring and Distributing Master Data \[Extern\]](#)

User Master Record

For further information about the central administration of user master data, refer to the ALE Implementation Guide (Transaction SALE).

*Modelling and Implementing Business Processes
Predefined ALE Business Processes
Cross-Application Business Processes
Central user administration*

Purchasing Info Record

When [Purchasing Info Records \[Extern\]](#) are distributed in the message INFREC the following data is transferred:

- General data and texts
- Purchasing organizational data and texts for purchasing organizational data

The following data is not distributed:

- Customs tariff preference data
- Order price history

The prerequisite is that the master records of the vendors and materials in question have already been distributed

The number ranges for purchasing info records need to be synchronized system-wide.

- When the IDoc for purchasing info records of a stock material is posted, if the purchasing info record for the material and the appropriate supplier does not already exist in the receiver system, the number of the purchasing info record is copied from the central system. Otherwise, the existing purchasing info record is updated.
- For purchasing info records for non-stock materials, the purchasing info record number is always copied from the central system. If a purchasing info record with the same number already exists, the system checks whether it has the same supplier and material group as the info record from the central system.

When a purchasing info record is posted, its conditions are not changed. However, the NETPR (net price) and EFFPR (effective price) fields are updated. In other words, the values are copied from the central system.

Distributable Master Data Objects

Conditions for info records must be transferred separately using the standard conditions distribution (message COND_A).

If the *PLANT* filter object is used in modeling the distribution of purchasing info records, the plant field must contain the value SPACE when you are working with purchasing info records which deal with more than one plant.

If the *Material* or *Material listing* filter objects are used for modeling the distribution of info records, the *Material* field must contain the value SPACE when you are working with purchasing info records for non-stock materials.

The *supplier listing* filter object cannot be used in the distribution of purchasing info records. Only material listings are allowed to be used as filter objects in the distribution of purchasing info records.

SAP provides the following enhancements:

- MMAL0003: ALE purchasing info record distribution: Outbound Processing
- MMAL0004: ALE purchasing info record distribution: Inbound Processing

For information on purchasing info records refer to the documentation *MM - Purchasing in Purchasing Info Records* [\[Extern\]](#).

Business Process

For further information about distributing business processes refer to the documentation *CO - Process Cost Accounting* under the topic: [Master Data in Process Cost Accounting](#) [\[Extern\]](#)

Classification

For the message type CLFMAS the dependencies of other message types, such as MATMAS and CREMAS must be maintained in different filter groups.

Conditions

The message type COND_A is used to distribute [Conditions](#) [\[Extern\]](#).

Fields which are reduced are set to initial in the receiver system. If you reduce whole segments, these are deleted in the target system.

Conditions with use E (= bonus, conditions for later calculation) can only be distributed manually and not with the change document system.

Cost Center

When cost centers are distributed, the field CV_OTYPE for the joint venture object type is not distributed with them.

Customer Master Record

Addresses of contact persons are not distributed.

Long texts are not included in the change document system.

Distributable Master Data Objects

Activity Master Record

When [Activity Master Records \[Extern\]](#) are distributed in the message SRVMAS the following data is transferred:

- Activity basic data
- Short texts (multi-language)
- Short texts (multi-language)

The activity conditions must be distributed separately with the message COND_A.

If you want to distribute activity contracts or maintain the same master data centrally so that you can use it in other R/3 Systems, then you should distribute activity master records.

Activity master records or any changes made to them are distributed with the report RBDSESRV or with the SMD tool.

For more information see the documentation *MM - Services* in [Service Master Records \[Extern\]](#).

Vendor Master Record

When distributing vendor master data, reminder data is posted in inbound processing only to the default dunning area.

If you are using SAP Retail, you can also distribute values for vendor characteristics.

Material Master Record

Changes to the material type of a material cannot be distributed. The material type of a material (field MTART) can only be transferred to the receiving R/3 System, if you create a material, not if you change a material. A single material may therefore have different material types in different systems.

The production version segment (E1MKALM) is only used in outbound processing. You cannot import the information into an R/3 System. This information can, however, be processed by non-SAP systems.

For further information about distributing material master records see the SAP Library in the documentation *LO - Administration of Material Master Data* under [IDoc Types for Distributing Master Data \[Extern\]](#).

Source List

The message SRCLST is used to distribute [Source List Records \[Extern\]](#).

The prerequisite is that the master records of the vendors, materials and possibly contracts have already been distributed



Source list records referring to a scheduling agreement cannot be distributed, because scheduling agreements cannot be distributed using ALE.

If you use the *purchasing organization* filter object when modeling the distribution of source lists, the supplier field must contain a space if you are working with source lists which span more than one purchasing organization.

Distributable Master Data Objects

If you use the *Supplier* filter object when modeling the distribution of source lists, the supplier field must contain a space if you are working with source list records which are supplier-independent.

The *supplier listing* filter object cannot be used in the distribution of source lists. Only material listings are allowed to be used as filter objects.

SAP provides the following enhancements:

- MMAL0001: ALE source list distribution: Outbound Processing
- MMAL0002: ALE source list distribution: Inbound Processing

For more information see the documentation *MM - Purchasing* in [Maintaining the Source List \[Extern\]](#).

Human Resources: HR Master Data, Organizational Data

For more information see [Master Data Distribution \(Human Resources\) \[Extern\]](#).

Profit Center

Statistical key figures are not distributed.

Master data can only be maintained in the local system of the controlling area.

G/L Account

The EXTERNAL ACCOUNTING INFORMATION field in the company code segment is only included if new G/L accounts are created. Changes to this field are not posted. For security purposes, you have to do this manually.

Bill of Materials

Bills of material (BOM) are distributed with all items valid on the key date and, if applicable, with local object dependencies. Only simple bills of material can be distributed.

The distribution of bills of material does not include:

- Long texts for headers, alternatives and items
- Sub-items
- Global object dependencies these must exist in the system
- BOM history - only the status of the BOM on the key date is distributed.
- the BOM item objects, for example materials, documents and classes. These objects must be distributed separately from, and before, the BOM.
- If applicable, the change number. The change number must exist in the system.

If you send bills of material directly, the user receives a list of all bills of material selected by the system which can be manually edited afterwards. Because only simple BOMs can be distributed, the user cannot select relevant alternative and variant BOMs, plant assignments and material variants for distribution.

You can overwrite the selection date displayed on the selection screen in the detail list. You can also replace it with a change number. For maintenance in the target system, you can also give a

Distributable Master Data Objects

valid-from date or a change number (engineering change management). If you do not change it, the valid-from date or change number is copied from the sending system.

Here are the message variants for message type BOMMAT:

- CNG (change, standard): Changes the BOM items.
The BOM header data remains unchanged. It creates the BOM in the target system, if it is not already there. This is the default if you do not select a message variant.
- CRE (create): Creates the BOM.
If the BOM already exists in the target system, the IDoc is not posted.
- DEL (delete): Deletes the BOM.
You should use this function with the utmost caution, since the deletion of the BOM also deletes references from other applications (such as routing and production orders).

Changes to simple material BOMs or BOM items can also be distributed with the SMD tool. This way you can identify items in the target system using the fields, item category, item number, sort string and object. The object field is dependent on item category material, document data and class data.

Value Scale and Quota Scale

In SAP Retail characteristics must be distributed before value and quota scales. Characteristics are not distributed with value and quota scales. For more information see the SAP Retail documentation under [Material Group: Value and Quota Scales \[Extern\]](#).

Cross-Application Business Processes

Bank Distribution

Bank Distribution

Use

When you create and change bank data and associated organizational addresses in different systems belonging to an SAP system group, every system displays the current bank data. As soon as you have saved bank data in one system, the data is sent on to other systems.

With the ALE business process, all changes to bank data are handled using a consolidation system. The local systems send all changes to the consolidation system and the consolidation system sends all changes back to the local systems. Bank data can also be edited in the consolidation system.

Integration

Functions in the distributed systems

Editing of bank master data can be carried out in all systems. You can find more information on this in the SAP Library under *Bank Directories* in the *Financial Accounting* → *Bank Accounting* area.

Restrictions with distribution of banks

If you no longer wish to use bank data that has become obsolete, you set a deletion flag in the local system for the relevant bank. The deletion flag is then copied to other systems in order that the other systems also know that this bank data is no longer up-to-date.

It is **not** possible to delete individual banks in local systems. In the activity [Delete Bank Master Data \[Extern\]](#) under Bank Directory in Customizing for *Cross-Application Components*, you can delete all banks for a particular country in a local system. This database change is **not** distributed, in other words, in the other systems that together form an SAP system group, these banks are not selected.

You can find further information in [Setting Deletion Indicators for Bank Master Data \[Extern\]](#).

Prerequisites

You have configured the same country-specific checks for all systems. You do this in Customizing under *General Settings* → *Set Countries* → [Set Country-Specific Checks \[Extern\]](#).

Activities

In Customizing, choose *Cross-Application Components* → *Predefined ALE Business Processes* → *Cross-Application Business Processes* → Configure Bank Master Data Distribution or *Basis Components* → *Application Link Enabling (ALE)* → *Configure Predefined ALE Business Processes* → *Cross-Application Business Processes* → Configure Bank Master Data Distribution.

You can find further information on Application Link Enabling (ALE) in the SAP Library under *Basis Components* → *Middleware (BC-MID)* → *Application List Enabling (BC-MID-ALE)*.

Central User Administration

Within an R/3 integrated system there are several systems with several clients. The same user master records must always be maintained in each client.

To avoid having to duplicate the maintenance of user master records, they are maintained in one central system.

To distribute data using ALE, the system landscape must first be set up. Proceed as follows:

Define Logical Systems

1. Call transaction SALE.
2. Choose *Sending and Receiving Systems* → *Logical Systems* → *Define Logical System*.
3. To enter new logical systems in the list, choose *Edit* → *New entries*.
4. In the column *Log. System* enter a short name in upper case. This will be the system ID used within the ALE integrated system. In the column *Name*, enter a long text name.



We recommend you choose a combination of the system name and client name as the short name. For example, for system BIZ with client 008 you could choose BIZCLNT008.

5. Once you have entered all the logical systems, choose *Save*.

Assigning Clients to Logical Systems

1. In transaction SALE choose *Sending and Receiving Systems* → *Logical Systems* → *Assign Client to Logical System*. Select a record and choose *Detail*. The *Detail* screen appears. In the field *Logical system* enter the name of the logical system you want to assign the logical system to and save your entry. Remember to use upper case.
2. Assign a client to all the logical systems of the central user administration.

Defining Target Systems for RFC Calls

To define the RFC destinations for the logical systems choose *Sending and Receiving Systems* → *Systems in Network* → *Define Target Systems for RFC Calls*. The RFC destination parameters control the remote function call.



An RFC destination is always created from the client you are logged on to. If you want to create an RFC connection from client 008 to client 322, you have to be logged on to client 008. Note that, in the context of central user administration RFC connections always require a connection in both directions. To define the RFC destination completely, you therefore have to logon to client 322 and define client 008 as the RFC destination.

1. Enter the name of the RFC destination. The name of the RFC destination should match the name of the relevant logical system (e.g. B:B20CLNT323). Remember to use upper case.
2. In the field *Connection type* enter the digit 3, if the connection is to a different R/3 System.

Central User Administration

3. In the field *Client* enter the target client number. In fields *User* and *Password* enter the system users already set up for the internal system communication within the ALE environment. Save your entries.

Creating the Distribution Model

Once you have set up the ALE environment, you have to define a system as the central system for the central user administration.

1. Logon to the system you want to use as the central system and call transaction SCUA.
2. Create a distribution model. Enter a name and choose *Create*. In the next screen enter the receiver systems.

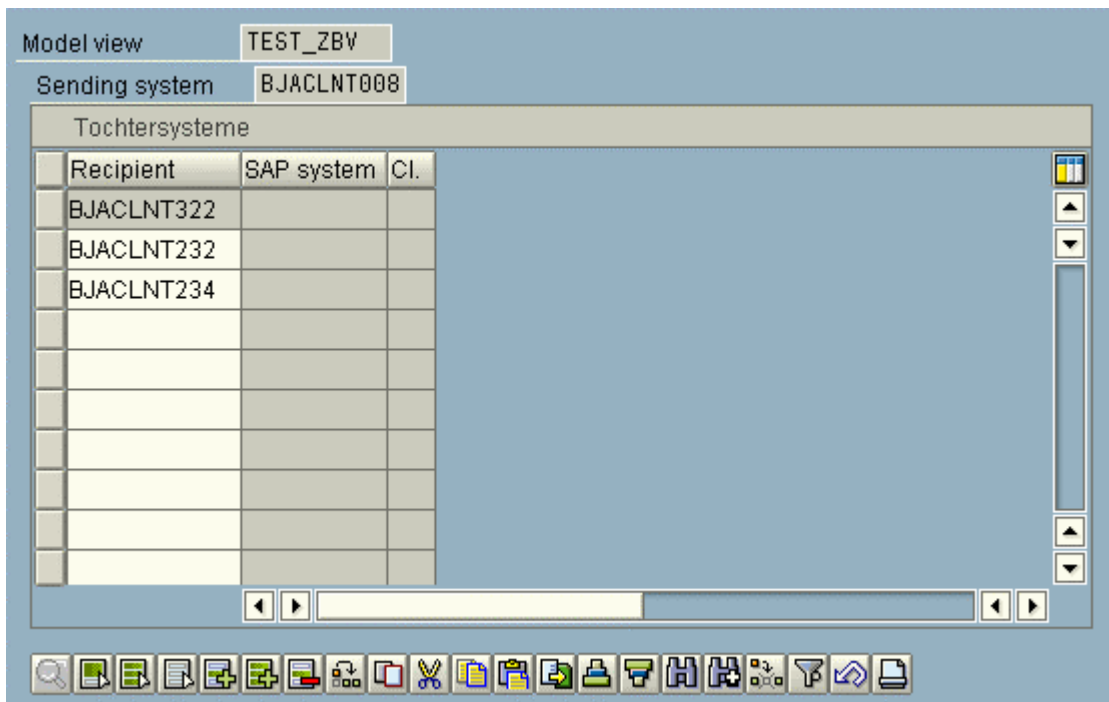

3. Save your entries.

The following activities are carried out automatically when you save.

- For each receiving system one BAPI is created for the object USER and the method CLONE (create user with template from other systems) and one BAPI for the object USERCOMPANY and the method CLONE.
- The partner profiles are generated for the sub-systems and for the central system.
- The distribution model is sent to the sub-systems.

Then several logs appear to generate the partner profiles. Check that the partner profiles have been created successfully.

To confirm that the distribution model will be used as the basis for the central user administration, save the model view again on the screen *Maintenance of System Landscape*.

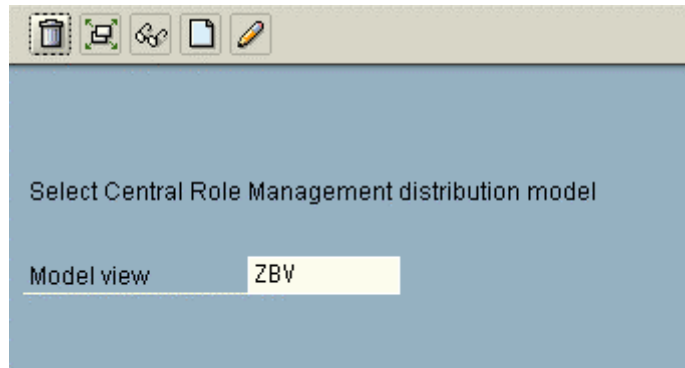

Saving the model assignment for the central user administration automatically triggers the distribution of the complete distribution model to all the sub-systems. After the model has been distributed to all the sub-systems no more users can be created. Only now is one system defined as the central system and the other systems as the sub-systems of the central user administration.

If the central user administration is to be set up in a different distribution model that has already been defined, delete the name of the model view using the symbol . Enter a different name or use the input help and save the name.

By selecting the symbol  you can send the distribution model to the sub-systems.

To delete the logs belonging to a distribution model, choose *Distribution model* → *Delete all data*.

In transaction BD64 you can change distribution models. Here you can also delete distribution models no longer needed.

Defining Distribution Parameters for Fields

Users can no longer be created in the sub-systems. However, users already created can be maintained in the sub-systems of central user administration. It is best to specify at field level, if, and in what respect these users are to be maintained.

1. Start transaction SCUM in the central system.
2. Define the distribution parameters for the fields.

Attribute:	Description:
Global	Data can only be maintained in the central system and is distributed to the sub-systems.
Local	Data can only be maintained in the sub-system and is not distributed.
Default value	A default value is maintained when you create a user and is distributed to all the sub-systems. Once it has been distributed, the data can only be maintained locally. If a new sub-system is connected to the central user administration, the default value is distributed to this system. If the default value is changed in the central system, the new value is distributed to new systems. It is not distributed to existing systems.

Central User Administration

Redistribution	Data can be maintained in both the central system and in the sub-system. If data is changed in the sub-system, it is redistributed to the central system and from here distributed to the other sub-systems.
Everywhere	Data can be maintained in both the central system and in the sub-system. If data is changed in the sub-system, it is not redistributed.



By scrolling you can display hidden fields.
You can find parameters belonging to other groups in the other tab pages.

3. Save the distribution parameters. They will automatically be copied to the receiving systems.

Transferring Users from New Systems

Existing user master records in sub-systems that are connected to the central system of the central user administration must be migrated to the central system so that they can be maintained centrally here.

1. Start transaction SCUG in the central system.
2. Select the sub-system from which the user data is to be migrated.
3. Choose *Transfer user*.

The following tab pages appear:

New users	These users are not yet included in the central user administration. You can transfer the selected users to here by choosing <i>Transfer user</i> . All the user parameters, such as address and logon information as well as profile and roles are transferred. From now on the user is maintained in the central system.
Identical users	Different users with identical user IDs.
Different users	These users are already included with the same name in the central user administration. You can transfer the profile and roles of the selected user to the central user administration by choosing <i>Transfer user</i> . From now on the user is maintained in the central system.
Existing central users	These users are already included with the different user IDs in the central user administration. Presently they cannot be transferred. Copy these users in the sub-system to the correct centrally-maintained user name or correct the user name in the user address so that it can be included in the next step.

For more information see the documentation *Users and Roles (BC-CCM-USR)* in [Central User Administration \[Extern\]](#).

Logistics

This section contains details of ALE business processes between R/3 Logistics Components and other R/3 Components.

Distributing Master Data

Distributing Master Data

This section describes how master data is distributed in Logistics.

ALE Transfer of Configuration Data

Use

This document describes ALE (Application Link Enabling) distribution of master data for variant configuration between R/3 systems. ALE can be used in R/3 Release 3.0, 3.1, and above.



For information on setting up ALE Customizing, see the SAP Library *Cross-Application Functions* → *(Business Framework Architecture)* → *ALE Business Process Library* → *ALE Quick Start*.

Distribution of Master Data

This is the menu path for distributing master data:

up to 3.1: *Logistics* → *Central functions* → *Distribution*

as of 4.0: *Tools* → *(Business Framework)* → *ALE* → *Master Data Distribution*
or transaction BALE.

Examples of menu paths in the ALE transaction:

- Distribution of characteristics: *Logistics* → *Classification System* → *Characteristic* → *Send*
- Distribution of materials: *Cross-Application* → *Material* → *Send*

The data to be transferred is interdependent, so we advise you to transfer data in the sequence shown here.

However, your existing data may require you to use a different procedure or to transfer data multiple times.

1. Characteristics and Characteristic Values

Most objects for variant configuration are dependent on characteristics. For this reason, characteristics must be transferred first.

Characteristics with value hierarchies, long texts for characteristic values, or linked documents may lead to problems during transfer.

Message type: CHRMAS

Availability: as of Release 3.0

2. Classes

When you use ALE to distribute classes, the characteristic assignments are also transferred.

Message type: CLSMAS

Availability: as of Release 3.0

3. Variant Table Structures

These are the variant tables that are created to support data maintenance.

Message type: VTAMAS

Availability: as of Release 3.1

4. Variant Table Contents

Once the structures of the variant tables have been distributed, their contents can be transferred.

ALE Transfer of Configuration Data

Message type: VTMMAS
Availability: as of Release 3.1

5. User-Defined Functions (Variant Functions, VC Functions)

User-defined functions in variant configuration let you use function modules that you have written, to check and infer characteristic values.
The distribution of functions only transfers the framework (texts, characteristics, and so on). The function modules that belong to the functions must be transferred first, using the usual R/3 transport system.

Message type: VFNMAS
Availability: as of Release 4.5

6. Object Dependencies (Except Constraints)

Dependencies (preconditions, selection conditions, procedures, and actions) usually refer to characteristics, characteristic values, variant tables, and variant functions. For this reason, dependencies must be distributed after this other master data. The dependencies transferred here are global dependencies. Local dependencies are transferred with the objects to which they are assigned. For example, if you created a selection condition as a local dependency for a BOM item, this dependency is transferred when you use ALE to distribute the BOM (bill of material).

Message type: KNOMAS
Availability: as of Release 3.1

7. Constraints

Constraints can only be distributed as of Release 4.5.

Message type: KNOMAS
Availability: as of Release 4.5

8. Constraint Nets

Constraint nets can only be distributed as of Release 4.5.

Message type: DEPNET
Availability: as of Release 4.5

9. Assignment of Dependencies to Characteristics and Characteristic Values

The characteristics are transferred once more to do this. Start ALE distribution for characteristics again, and the system transfers the assignments.

See point 1: Characteristics and Characteristic Values

10. Configurable Materials

Depending on how many configurable materials you have, you can use ALE to distribute them or create them in the target system. The other materials in BOMs for configurable materials are transferred to the target client by the usual data transfer.
Material variants cannot be distributed by ALE.

Message type: MATMAS
Availability: as of Release 3.0

11. Configuration Profiles

Configuration profiles must be distributed after the configurable materials, because the key of the material identifies the profile. During the ALE process, the dependencies for the

ALE Transfer of Configuration Data

configuration profile are also transferred, and are reassigned to the profile in the target client.

Message type: CNPMAS
 Availability: as of Release 3.1

12. Classification

You only need to distribute classifications if you have classified materials.

Message type: CLFMAS
 Availability: as of Release 3.0

13. Bills of Material

Material BOMs for configurable materials can be distributed using ALE. The transfer also assigns the dependencies for BOM items to the items. Make sure that the dependencies and all the materials required already exist in the target system.

If material variants are assigned to the BOM, there may be problems transferring the super BOM.

Message type: BOMMAS
 Availability: as of Release 3.1

Availability of Engineering Change Management for ALE Objects

Data created with engineering change management can be transferred as of the release shown below. However, first the change numbers must already exist in the target system. You can create them manually if required.

As of Release 3.0: material master records

As of Release 3.1: BOMs, dependencies, configuration profiles, and variant table contents

As of Release 4.0: characteristics, classes, and classifications

As of Release 4.5: constraints and constraint nets

Message Types for Further Objects in the Variant Configuration Environment

Object	Message Type	Availability
Change objects	ECMMAS	as of Release 4.5
Conditions	COND_A	as of Release 3.1H
Cost centers	COSMAS	as of Release 3.0
Cost center groups	COGRP	as of Release 3.1
Activity type	COAMAS	as of Release 3.0
Activity type groups	COGRP5	as of Release 3.1
Cost elements	COELEM	as of Release 3.0

ALE Transfer of Configuration Data

Cost element groups	COGRP2	as of Release 3.1
Prices	COACTV	as of Release 3.0
Units of measure	COCOKA	as of Release 3.0

Work Breakdown Structure or Internal Order Distribution

Use

To carry out actual postings in distributed systems for internal orders and work breakdown structures, you can distribute the master data and status information of internal orders and work breakdown structures to more than one system.

Integration

Functions in the Master System

All functions for internal orders and work breakdown structures are available. However, in the master system you cannot call up the corresponding line items from line item reports if the line items all come from one receiving system.

You create the internal orders or the work breakdown structures in the master system. When you save them, the R/3 System distributes them automatically to one or more receiving systems. Through the filter objects Controlling area and order type or project profile, you control whether, and in which system, the internal orders or work breakdown structures are to be distributed.

You can also send released internal orders and work breakdown structures at a later date.

Functions in the Receiving System

- Master data and status information display
You can only make changes in the original master system. These changes are transferred to the receiving systems.
- Postings from other R/3 components (such as, FI, MM)
- Assessment
- Distribution
- Periodic reposting
- Manual reposting (costs, revenues, line items)
- Direct and indirect activity allocation
- Reposting internal activity allocation
- Accrual calculation
- Settlement debits
- Line item reports

Restrictions with Distributing Internal Orders and Work Breakdown Structures

- WBS elements cannot be distributed individually. Only complete work breakdown structures are distributed.
- If a WBS element is assigned to an internal order, the system does not automatically distribute this WBS element to the receiving system. This means that the assignment of the WBS element to the internal order is not known in the receiving system.

Work Breakdown Structure or Internal Order Distribution

If required, you can distribute the work breakdown structure first to the receiving system and then later on distribute the internal order.

- If you settle activities of cost centers that do not exist in the master system, you can only settle the internal order or work breakdown structure using settlement type FUL.

The following business transactions are not possible in the receiving system:

- Planning of internal orders, costs, and appointments on work breakdown structures
- Budgeting and availability control
- Commitment postings
- Overhead costing
- Settlement of internal orders and WBS elements
- Assignments of orders and networks to the work breakdown structure



If you set the deletion indicator in the master system for an internal order or a work breakdown structure and this change was adopted in the receiving system, the R/3 System also deletes the given internal order or work breakdown structure in the receiving system. To ensure that in the receiving system you cannot make postings to deleted objects, you should choose a time period corresponding to the setting of the deletion flag and the setting of the deletion indicator (for example, for internal orders by setting residence time 1). You must make sure that the *Deletion flag* status has been adopted in all receiving systems **before** you set the deletion indicator in the master system.

Data Flow

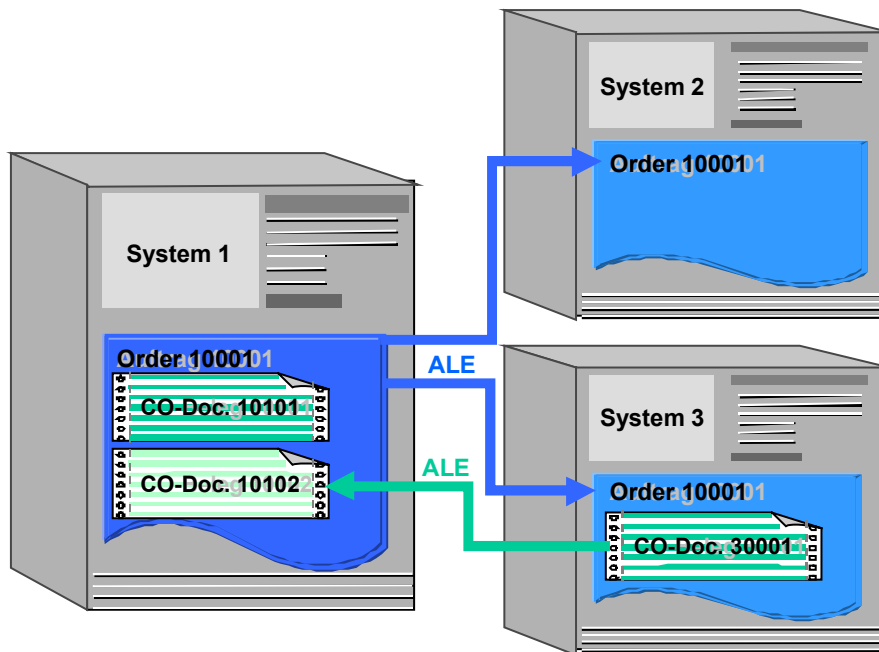

The data flow between distributed systems is identical for internal orders and work breakdown structures. This is described using the example of an internal order:

If you create or change internal order 10001 in system 1, it is automatically distributed to the receiving systems (in this case: system 2, system 3) and created or changed there using the same order number. System 1 is the master system of internal order 10001.

- Postings made in the master system are only available in the master system (CO document 10101 in this case).
- Postings made in other receiving system (in this case, system 3) are sent via ALE to the master system. They are available in the both the receiving system and in the master system (in this case, CO doc. 30001 from system 3 is given its own number CO doc. 10102 in the master system).

Prerequisites



Whenever possible, you should carry out all cross-system Customizing settings in **one** system.

- The **organizational units** (e.g. controlling area, company code) are defined **identically** in the master system and the receiving systems.
- The **order type** or the **project profile** are defined **identically** in the master system and in the receiving systems.
- The **status selection profiles** are defined **identically** in the master system and in the receiving system.

Work Breakdown Structure or Internal Order Distribution

- For internal orders: The **number ranges** are defined **separately** in the master system and in the receiving system. This is because a distributed internal order in the receiving system is given the same number as in the master system.

or work breakdown structures: The **project edit screens** are defined **identically** in the master system and in the receiving systems. In the receiving systems you should include a lock indicator for the project edit screens, so that these project numbers cannot be used for new projects.

Activities

In the Implementation Guide (IMG), choose *Basis Components* → *Distribution (ALE)* → *Predefined ALE Business Processes* → *Accounting* → *Master Data Distribution* → [Distribution of Internal Orders \[Extern\]](#) or [Distribution of Work Breakdown Structure \[Extern\]](#).

Use the following objects:

Business object	<i>Work Breakdown Structure</i>	<i>Internal Order</i>
Distribution method	<i>SaveReplica</i>	<i>SaveReplica</i>
Message type		<i>INTERNAL_ORDER</i>

To send internal orders and work breakdown structures at a later time, choose *Tools* → *ALE* → *Master data distribution* → *Accounting* → *Internal Order* or *Projects* → *Send*.

For more information about *ALE* see the SAP Library under *Basis* → *Middleware* → *ALE-Introduction and Administration*.

Logistics <-> Logistics

This section contains details of ALE business processes between R/3 Logistics Components.

Sales and Operations Planning (PP-SOP)

Sales and Operations Planning (PP-SOP)

The ALE scenario for Sales and Operations Planning (SOP) is an important application in which information structure distribution is used.

Sales and Operations Planning (SOP) covers various activities including the specification of medium term and long term sales volumes and the approximate planning of the production activities that are required to meet these volumes. The enormous amount of data involved means that this is not a highly detailed form of planning with exploded bills of materials and scheduling via routing, but rather a rough estimate of the feasibility of the proposed plans.

The principle of SOP

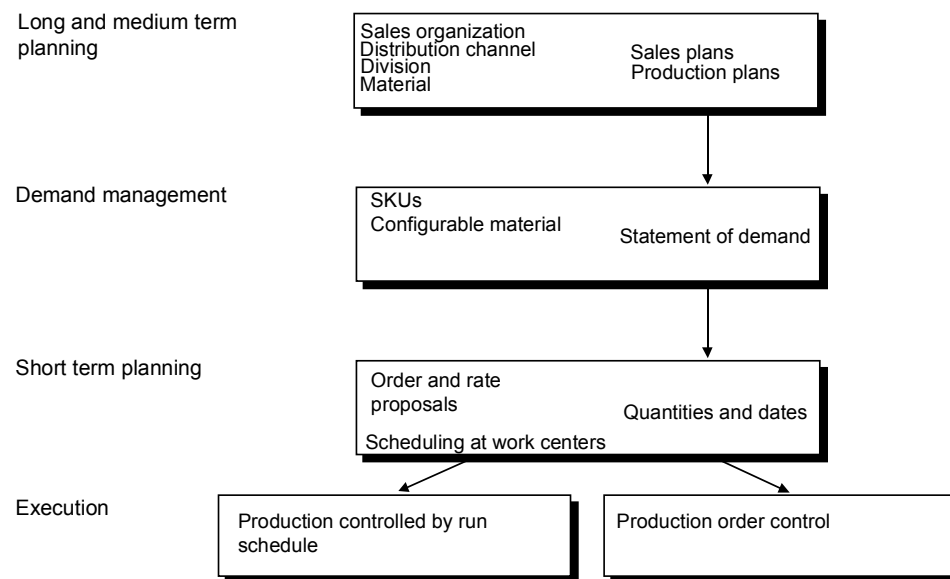

SOP can be done at the level of finished products or using product groups. Any combinations of materials or even of product groups themselves can be grouped together into other product groups.

The exact breakdown is done at the level of the material and the plant.

A comprehensive description of SOP can be found in the function description for “the SAP production planning system”.

In the ALE distribution scenario for SOP there is both a central planning system and decentral systems that can also perform planning tasks:

- In the central system, planning can be performed at the product group level.
- Material and plant are separated out of the completed central planning and are passed to the decentral planning.
- The key figures that were preset centrally are compared to the decentrally planned key figures.

Sales and Operations Planning (PP-SOP)

- An example would be the “quantity – centrally preset value” key figure, within which the central system plans, and the “quantity – decentrally preset value” key figure, within which the decentral units plan.
- Afterwards the decentral key figures are sent back to the central system. This kind of planning is also called concurrent planning.

This planning mechanism allows the entire planning to be viewed in the central system.

Concurrent SOP planning

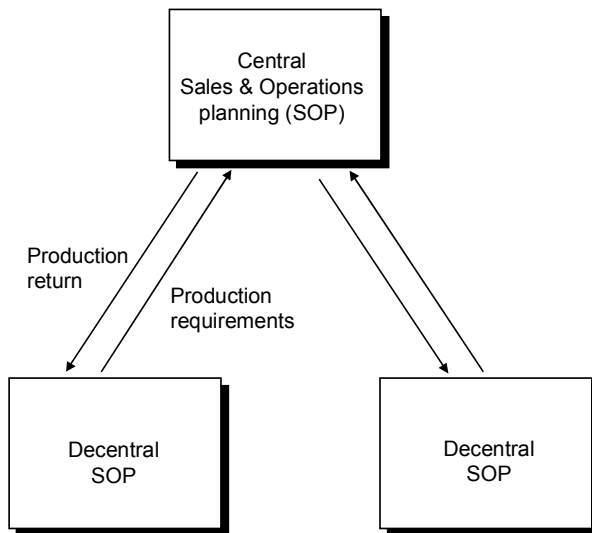

Restrictions

SAP delivers standard information structures. The customer can create any information structures he wishes based on these.

The SOP data can only be distributed between information structures that are identical across the different systems.

Distribution Reference Model

The approximate sales volume planning is performed plant by plant.

Distribution Reference Model for SOP

Sales and Operations Planning (PP-SOP)

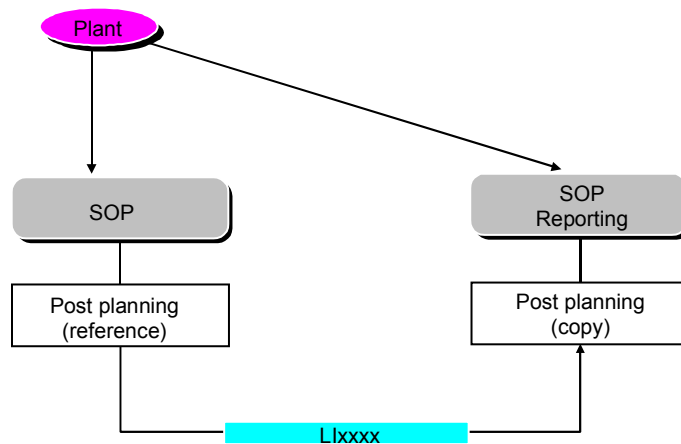

Structure of IDocs

Since customers design their own information structures, the IDoc structure also has to be flexible.

A message type is defined for each information structure that has to be distributed. The IDoc type is always the same.

An allocation table defines which actual fields correspond to which general IDoc fields.

The optional segments shown are there for customers who want to send several key figures. Since there is a technical limit to the amount of data a segment can accept, the number of segments required depends on the quantity of data.

Segments that are not required in the IDoc are omitted. (For example: A customer uses 10 key figures for data exchange. Only one key figure segment is constructed, because the upper limit for the amount of data in the segment has not been exceeded.)

Master Data to be Distributed

- The material master (core data)
- Product group master (implicit in the material master)

Control Data to be Distributed

The control data that has to be distributed for this scenario is detailed in the ALE Implementation Guide.

Separate Sales and Shipping (SD-SLS, SD-SHP)

Separate Sales and Shipping (SD-SLS, SD-SHP)

This business process is based on the business process "Stock Transfer between Distributed Systems". The idea of it is that several decentrally operating sales units initiate sales orders directly at a central shipping point.

[Description of the Scenario \[Extern\]](#)

[Structure of the IDoc \[Extern\]](#)

[Master Data To Be Distributed \[Extern\]](#)

[Functional Restrictions Compared to an Integrated System \[Extern\]](#)

[Prerequisites \[Extern\]](#)

Stock Transfer Between Distributed Systems (SD, MM)

The principle of this business process is that decentralized R/3 Systems can obtain goods from other R/3 Systems through purchasing; these other systems sell the goods to purchasing. The latter R/3 Systems sell the goods to purchasing.

[Description of the Scenario \[Extern\]](#)

[Structure of the IDoc \[Extern\]](#)

[Master Data To Be Distributed \[Extern\]](#)

[Control Data To Be Distributed \[Extern\]](#)

[Serialization \[Extern\]](#)

[Functional Restrictions Compared to an Integrated System \[Extern\]](#)

Logistics <-> Human Resources

Logistics <-> Human Resources

For details of ALE business processes between Logistics Components and Human Resources Components see *Human Resources*.

Logistics <-> Accounting

The distribution is based on the distribution mechanisms in Accounting. The applications in the R/3 Logistics system forward the documents to the Accounting system, running in the background, which then distributes the information.

Only R/3 Logistics systems can be connected to R/2 or R/3 Accounting systems.

R/3 Logistics systems are business R/3 Systems for business areas or systems that include a plant with material management, production planning or plant maintenance functions.

See also:

[Central Accounting - Decentralized Logistics \[Extern\]](#)

[Decentralized Accounting - Central Logistics \[Extern\]](#)

[Several Accounting Systems - Several R/3 Logistics Systems \[Extern\]](#)

[Information Flow for Financial Accounting \[Extern\]](#)

[Data Transfer Between Accounting and Logistics \[Extern\]](#)

[Functional Limitations \[Extern\]](#)

Human Resources

Human Resources

This section contains details of ALE business processes involving the Human Resources Component, other R/3 Components and external components also.

Human Resources <-> Human Resources

This section contains details of ALE business processes between R/3 Human Resources Components in distributed systems.

Distribution of Trip Costs

Distribution of Trip Costs

Use

Data is exchanged between the decoupled, logical application components *Travel Management* and *Payroll*, which constitutes part of the *Human Resources* (HR) System. You enter trip costs in *Travel Management*. The trip costs are collected, and then distributed to the separate HR *Payroll* application component. The *Transferred to HR Payroll* status is assigned to the trip costs. The *Payroll* application component processes the trip costs, pays them, and taxes them accordingly.

Integration

The *Distribution of Trip Costs* interface is supported by ALE. The interface is provided as follows:

- By local access to customizing data
 - To retrieve possible period data, you must transfer tables T549Q (Payroll Periods) and T549A (Payroll Accounting Areas).
- By synchronous communication
 - To set the correct payroll period, the *Payroll* control record is read synchronously in the *Payroll* System.
- By asynchronous communication
 - Trip cost results are transferred asynchronously from *Travel Management* to *Payroll*.
 - Retroactive accounting data is set automatically.

Activities

Call up the R/3 library and see *CA - Cross-Application Components* → *ALE Business Process Library*.

Human Resources <-> Logistics

This section contains details of ALE business processes between R/3 Logistics Components and Human Resources Components.

Confirmations from PP, PI, PM, CS, and PS

Confirmations from PP, PI, PM, CS, and PS

Use

The *Confirmations from PP, PI, PM, CS, and PS* interface supports the transfer of order confirmations from *Production Planning and Control* (PP), *Process Industries* (PI), *Plant Maintenance* (PM), *Customer Service* (CS), and *Project System* (PS) to the *Personnel Time Management* component in the *Human Resources* (HR) System. Performance-based payments are effected to employees on the basis of such order confirmations.

Integration

Order confirmations are transferred asynchronously via ALE (using BAPIs).

Prerequisites

You must enter order confirmations in *Logistics* (LO) for a personnel number. The personnel numbers and wage types are checked locally in the LO System. The time recording ID numbers are converted to personnel numbers in the LO System. Therefore, you must replicate HR master data and customizing tables for wage types.

Features

The *Confirmations from PP, PI, PM, CS, and PS* interface is used for confirmations entered manually in the LO System, and for confirmations collected from a plant data collection system (PDC, communication channels 2, 3, 4, 5). You can enter the confirmations for PP, PM, CS, PS, and PI as time tickets (hours worked). You can also enter confirmations for PP and PI as time events (start of working time, end of working time).

Time ticket confirmations from PP and PI are posted as time tickets to the HR *Incentive Wages* component. Time ticket confirmations from PS, PM, and CS are posted as attendances to the HR *Personnel Time Management* component. Processing time tickets in HR has no effect on LO.

Time events are transferred to PDC time events in *Personnel Time Management*. Time tickets are generated automatically on the basis of these time events, and then transferred to the HR *Incentive Wages* component for performance-based payments. To correct errors, you can use Remote Function Call (RFC) to maintain HR time events in the LO System. The corrections are transferred asynchronously to the HR System using the interface technology described above.

Activities

Call up the R/3 library and see *PT - Personnel Time Management*.

Business Event Attendees: Contact Persons

Use

Data on contact persons i.e. customer employees that can be booked as event attendees in *Training and Event Management* can also be administered in the R/3 component *Sales and Distribution (SD)*.

In this business process, data on contact persons is transferred from Logistics to the HR system via ALE. The transfer takes place synchronously via the RFC destination in Logistics. No IDOCs are transmitted during this process.

Integration

Functions in Training and Event Management

- Create, display, and change contact person attendee types by branching to *Sales and Distribution*.
- Prebook, book, cancel, rebook, and replace attendees of the type contact persons.
- Bill contact persons.
- Check existence of contact person.

Functions in Sales and Distribution

- Create, display, and change contact persons.
- Administer contact person master data.

Data Flow

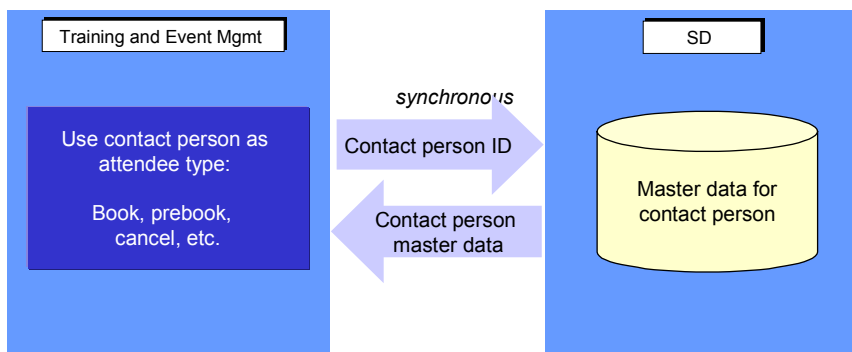

The data transfer takes place using synchronous communication. In *Training and Event Management*, the interface program **RHPART00** reads all existing segments of object **BusPartnerEmployee** with the **BusinessPartnerEmployee.ExistenceCheck** method in *Sales and Distribution*.

Business Event Attendees: Contact Persons**Prerequisites**

When specifying the object method, you must define the HR system as the sending system and the Logistics system as the receiving system.

The following entries must be made in ALE Customizing in the step [Maintain Distribution Model and Distribute Views \[Extern\]](#) under *Maintain method*:

CLIENT: HR System

SERVER: Logistics System

OBJECT: BusPartnerEmployee

OBJECT TYPE: BUS1006001

METHOD: BusinessPartnerEmployee.ExistenceCheck



You can find additional information on the ALE business process *Business Event Attendees: Contact Persons* in the IMG under [Business Event Attendee: Set Contact Person \[Extern\]](#).

Business Event Attendees: Customers

Use

Data on customers that can be booked as business event attendees in *Training and Event Management* is administered in the R/3 component *Sales and Distribution (SD)*.

In this business process, customer data is transferred from Logistics to the HR system via ALE. The transfer takes place synchronously via the RFC destination in Logistics.

Integration

Functions in Training and Event Management

- Create, display, and change customer attendee types by branching to *Sales and Distribution*.
- Prebook, book, cancel, rebook, and replace customers.
- Bill customers.
- Check existence of customer.

Functions in Sales and Distribution

- Create, display, and change customers.
- Administer customer data.

Data Flow

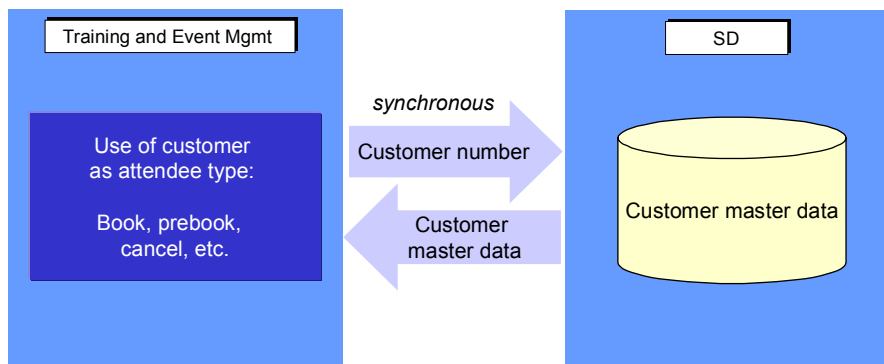

The data transfer takes place using synchronous communication. In *Training and Event Management*, the interface program **RHKUNA00** reads all existing segments in the **Customer** object with the **Customer.CheckExistence** method in *Sales and Distribution*.

Prerequisites

When specifying the object method, you must define the HR system as the sending system and the Logistics system as the receiving system.

Business Event Attendees: Customers

The following entries must be made in ALE Customizing in the step [Maintain Distribution Model and Distribute Views \[Extern\]](#) under *Maintain method*:

CLIENT: HR System

SERVER: Logistics System

OBJECT: Customer

OBJECT TYPE: KNA1

METHOD: Customer.CheckExistence



You can find additional information on the ALE business process *Business Event Attendees: Customers* in the IMG under [Business Event Attendee: Set Customer \[Extern\]](#).

Business Event Billing

Use

The *Billing Business Events* interface lets you bill attendance fees from *Training and Event Management* to *Sales and Distribution (SD)*. Data is transferred synchronously. No IDOCs are sent.

Integration

Functions in Training and Event Management

- Transfer card data to SD system if you use payment cards for billing
- Authorize payment card if check is passed successfully
- Determine the attendees to be billed for an event
- Transfer payroll data to the SD system
- Create a reference document for billing
- Compare document, i.e. checking billing
- Report on completed billing
- Check whether billing has been canceled
- Cancel billing documents
- Create credit memos
- Cancel credit memos

Functions in Sales and Distribution

- Check card if payment cards are used in billing
- Check completeness of billing data transferred from *Training and Event Management*
- Bill attendance fees
- Transmit document information for document comparison with *Training and Event Management*

Data Flow

Payment card check:

Business Event Billing

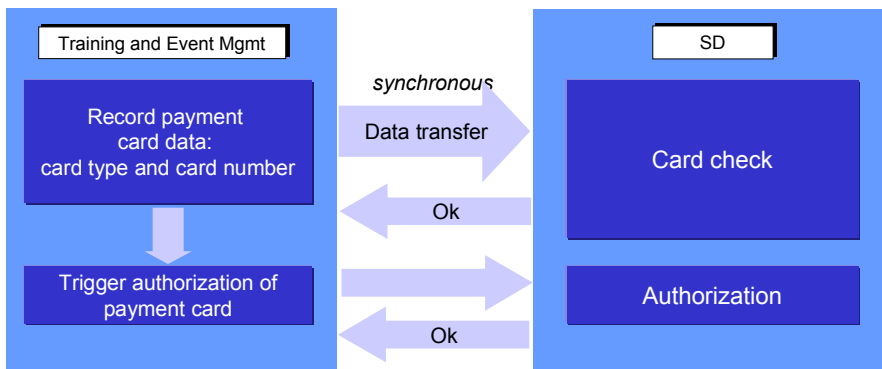

- When payment cards are used in the billing process, payment card data is stored in *Training and Event Management* during fee assignment (function *Book attendance* in the *dialog Book/Payment Info*). This data is transferred to *Sales and Distribution*, where a plausibility check is performed on the data. The result of this check is transferred to *Training and Event Management*. This data transfer takes place using synchronous communication. If the check validates the card, the card can be authorized in *Sales and Distribution*.

Perform billing:

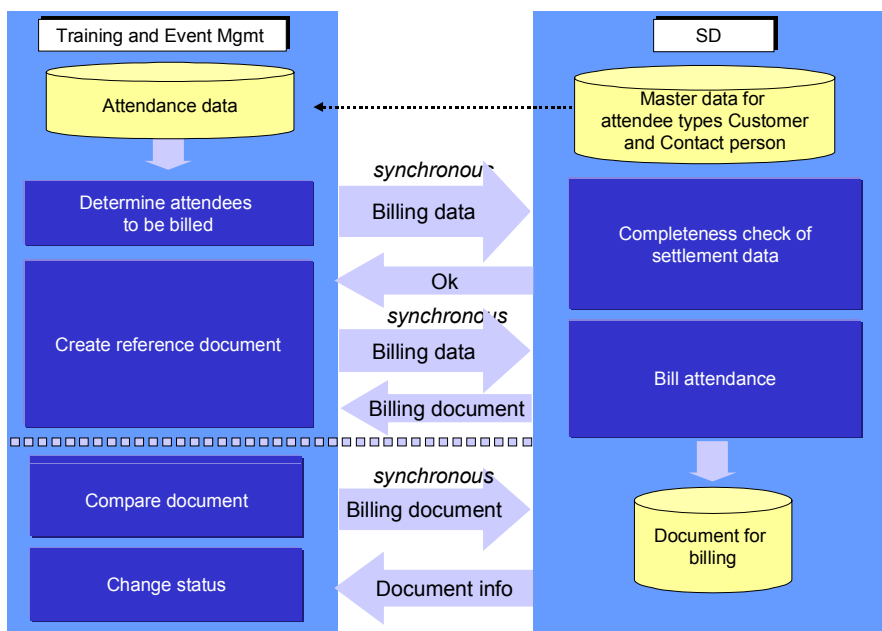

- In *Training and Event Management*, the report **RHFAKT00** determines what attendees are to be billed. The settlement data is transferred to *Sales and Distribution* where a completeness check is performed. This data transfer is realized using synchronous communication.

Business Event Billing

- In *Training and Event Management*, if there is a positive check result, a reference document is created and the settlement data is transferred to *Sales and Distribution*, via synchronous communication.
- In *Sales and Distribution*, billing is performed for the transferred attendees.
- In *Sales and Distribution*, a document comparison is performed, in which the reference number is transmitted to *Sales and Distribution*. Document information is sent back to *Training and Event Management* from *Sales and Distribution* (via synchronous communication).

Cancel billing document:

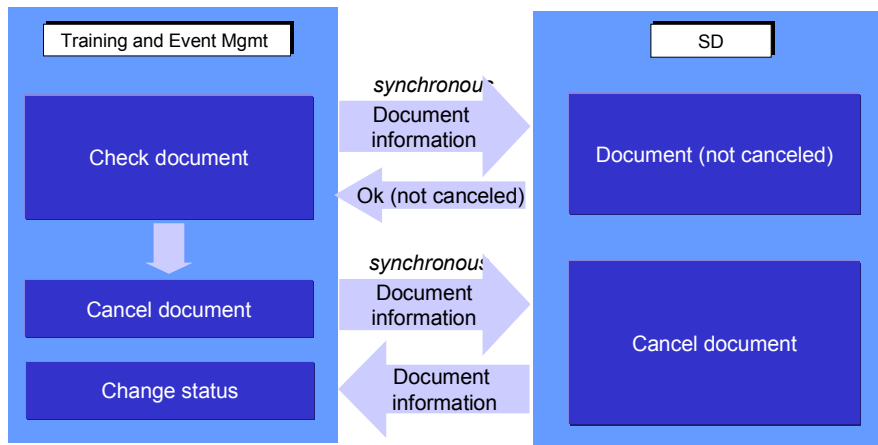

Prerequisites

- The sales organization data must be distributed, i.e. *sales organization*, *distribution channel*, and *division*.
- The customer distribution model must be maintained. When you are specifying the object method, you must define the HR system as the sending system and the SD system as the receiving system.

The following entries must be made in ALE Customizing in the step [Maintain Distribution Model and Distribute Views \[Extern\]](#) under *Maintain method*:

CLIENT: HR System
 SERVER: SD System
 OBJECT: PaymentCardServices
 METHOD: Checknumber
 OBJECT: ItCustBillingDoc
 METHOD: CreateFromData
 OBJECT: ItCustBillingDoc
 METHOD: Simulate
 OBJECT: ItCustBillingDoc

Business Event Billing

METHOD: IsCancelled

OBJECT: ItCustBillingDoc

METHOD: CancelFromData



It is planned to support the methods for object ItCustBillingDoc for one more release only.



You can find more information on the ALE business process *Billing in Training and Event Management* in the IMG under [Set Up Billing for Business Events \[Extern\]](#).

See also:

[Business Process Flow of Billing Business Events \[Extern\]](#)

Material Order in Training and Event Management

Use

The interface *Material as a Resource in Training and Event Management* lets users of *Training and Event Management* reserve resources that are managed as material in the *Materials Management* (MM) application component.

A *reservation* is created for stock material if it is available. A *purchase requisition* is created in *Purchasing* for non-stock material or material that is not currently available.

Integration

Functions in Training and Event Management

- Select and reserve material for a business event
- Determine the demand for a material for a business event
- Transmit demand to *R/3 Materials Management*
- Create a reference number for material reservation and/or purchase requisition
- Order material (transfer material reservation or purchase requisition)
- Check material order

Functions in Materials Management

- Check availability of material
- Create material reservation or purchase requisition
- Transmit material purchase requisition to *Purchasing*
- Stage material
- Transmit reservation or purchase requisition number

Material Order in Training and Event Management

Data Flow

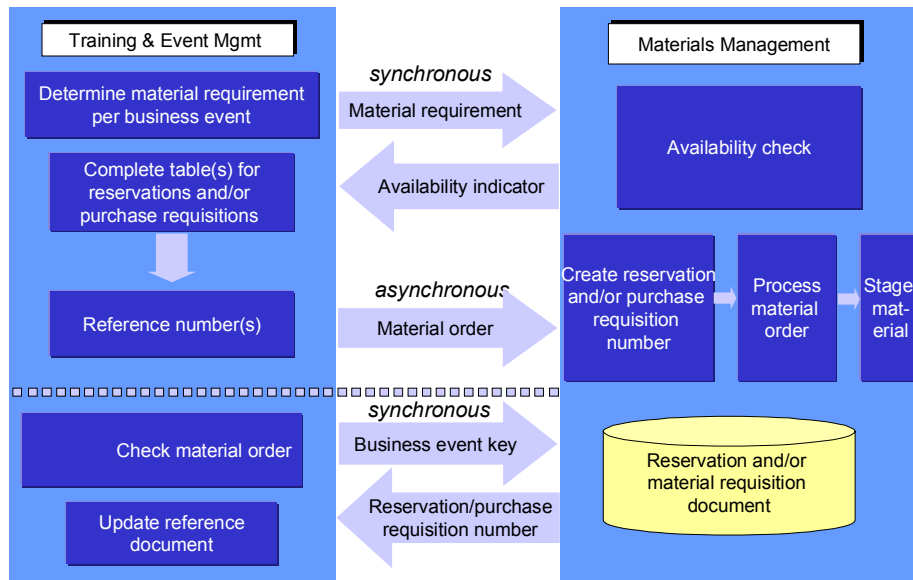

- In *R/3 Training and Event Management*, the report **RHMARP00** is used to determine the material requirements of a business event and transmit these to *R/3 Materials Management*. An availability check is carried out for the required material and an availability indicator is transmitted to *R/3 Training and Event Management*. This data transfer is realized using synchronous communication.
- In *R/3 Training and Event Management*, either a reservation or a purchase requisition is created depending on the availability indicator. This process generates either one or two reference numbers.
- Material data is transmitted using asynchronous communication to *R/3 Materials Management*, where a material reservation or a purchase requisition is created. The reservation or purchase requisition is further processed until the material is available.
- During material order checking (report RHMARP00), a check is carried out in *R/3 Materials Management* for the reservation or purchase requisition number using the business event key and the reference number is returned to *Training and Event Management* (via synchronous communication).

Prerequisites

- Release 4.5A or higher of both *Training and Event Management* and *Materials Management* since the material order was not supported in previous releases.
- In distributed systems, the customer distribution model must be maintained. This means that the HR System must be defined as the sending system and Logistics as the receiving system during object method specification.

Material Order in Training and Event Management

The following entries must be made in ALE Customizing in the step [Maintain Distribution Model and Distribute Views \[Extern\]](#) under *Maintain method*:

CLIENT: HR System

SERVER: Logistics System

OBJECT: Material

METHOD: GetList

OBJECT: MaterialReservation

METHOD: CreateFromData

OBJECT: Purchase Requisition

METHOD: CreateFrom Data

You can generate settings for the [Partner Profiles \[Extern\]](#) from the distribution model. For more information, refer to the ALE IMG under [Generate Partner Profiles \[Extern\]](#).



For more information on the ALE business process *Material as a Resource in Training and Event Management*, refer to the Implementation Guide (IMG) under [Set Material as a Resource in Training and Event Management \[Extern\]](#).

See also:

[Business Process Flow of Material Order \[Extern\]](#)

Availability of Employees in Logistics

Availability of Employees in Logistics

Use

The *Availability of Employees in Logistics* interface is used to secure the availability of persons in *Logistics* (LO). Availability data is required for:

- Scheduling orders with assigned persons
- Determining available labor capacity for capacity planning

Integration

The *Availability of Employees in Logistics* interface is provided by a BAPI. Data is not replicated. Instead, it is read synchronously from the *Human Resources* (HR) System by remote access.

Features

When determining the availability of persons, the *Availability of Employees in Logistics* interface takes account of all relevant time data in the HR *Time Management* application component.

Activities

Call up the R/3 library and see *PP - Production Planning and Control*.

Work Center Integration

Use

The *Logistics* (LO) work center is represented as an external object in the *Human Resources* (HR) entity relationship model (organization model). The *Work Center Integration* interface enables you to create relationships between LO work centers and HR organizational entities (such as HR organizational units and HR work centers). You can also create HR work centers in *Logistics* (LO).

Integration

The organization model is replicated by ALE from the HR System to the LO System, where it is evaluated locally. HR work centers created in the LO System can also be replicated from Logistics to HR.

Prerequisites

You must use ALE to replicate the organization model from the HR System to the LO System.

To create an HR work center in Logistics, use internal number ranges. Before replicating data, you must compare the internal number range of the HR work center in LO with the internal number range of the HR work center in HR. Data is distributed in both directions, which means that the numbers must be discrete and must not overlap. If numbers overlap, they could be overwritten when data is replicated.

Activities

Call up the R/3 library and see *PP - Production Planning and Control* → *PP Work Centers*.

Qualifications & Requirement Profiles in Logistics

Qualifications & Requirement Profiles in Logistics

Use

The *Logistics* (LO) application component enables you to enter qualifications for work centers in *Human Resources* (HR) and capacities. You can enter requirements profiles for orders, such as maintenance orders, production orders, service orders, process orders, and project orders. A requirements profile is a group of qualifications. The *Qualifications and Requirement Profiles in Logistics* interface enables you to define qualifications as requirements for HR work centers and capacities. You can assign requirements profiles to order operations.

Integration

Using ALE, qualifications and requirements profiles are replicated from the HR System to the LO System, where they are evaluated locally.

Prerequisites

You must use the ALE scenario for the organization model to replicate *qualification and requirements profiles* from the HR System to the LO System.

Activities

Call up the R/3 library and see *PP - Production Planning and Control*.

Assignment of Employees in Logistics

Use

You can assign employees in orders (such as maintenance orders, production orders, service orders, process orders, and project orders) according to various criteria, and depending on their HR data within the *Human Resources* application.

Integration

Using ALE, HR data and the organization model are replicated from the HR System to *Logistics* (LO), and evaluated locally in the LO System.

Activities

Call up the R/3 library and see *PP - Production Planning and Control*.

Daily Work Schedule at Logistics Work Center

Daily Work Schedule at Logistics Work Center

Use

When defining shifts within *Logistics* (LO), the *Daily Work Schedule at Logistics Work Center* interface enables you to use daily work schedules from *Time Management*, which constitutes part of the *Human Resources* (HR) application component. You can use this data in *Logistics* (LO) to schedule orders and determine the available capacity of a work center.

LO customizing table TC37A (Shift Definition) includes references to HR tables T550A (Daily Work Schedules) and T550P (Break Schedules).

Integration

HR daily work schedules are evaluated locally in LO using replicated customizing data.

Prerequisites

HR daily work schedules and break data must be read locally in the LO System. For this reason, HR *Time Management* customizing tables T550A and T550P must be replicated in the LO System using ALE.

Activities

Call up the R/3 library and see *LO - Logistics - General*.

Human Resources <-> Accounting

This section contains details of ALE business processes between R/3 Human Resources Components and Logistics Components.

Posting Payroll Posting Documents

Posting Payroll Posting Documents

Use

When you post payroll results to Accounting, all posting information from the payroll results is selected, summarized, formatted, and posted to the Accounting components.

For more information on the posting procedure and on business administration aspects, see the SAP Library for Payroll under [Posting to Accounting \[Extern\]](#).

For more information, see Customizing for *Payroll* under *Reporting for Posting to Accounting*.

Integration

The posting documents created in a posting run in the *Payroll Accounting* component (PY) can be posted to the following components in Accounting:

- Financial Accounting (FI)
 - General Ledger Accounting (FI-GL)
 - Accounts Payable (FI-AP)
 - Accounts Receivable (FI-AR)
 - Special Purpose Ledger (FI-SL)
 - Funds Management (FI-FM)
- Controlling (CO)

Functions in the Payroll System

- Determination of accounts
- Determination of vendors and customers
- Determination of posting period from fiscal year variant
- Account assignment checks
- Read fixed account assignments for cost elements
- Read value-added tax indicator
- Validation of document data against data from Accounting
- Read short texts for G/L accounts
- Read short texts for vendors and customers
- Display of accounting document

Functions in the Accounting System

- Posting of payroll documents to Accounting components
- Display of payroll document

Data Flow

Posting between systems from 4.0A

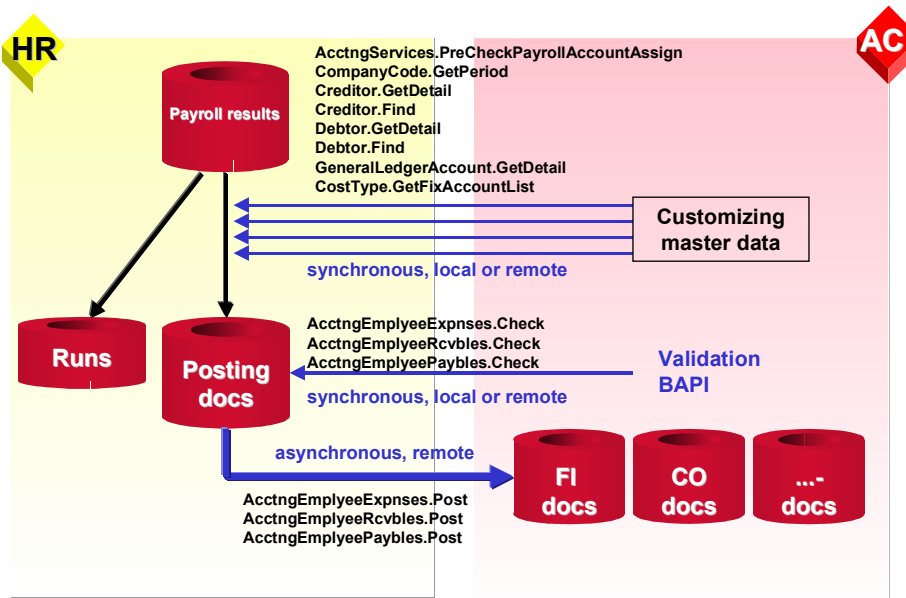

Before each cross-system activity, the HR system determines the receiving system based on the entries in the distribution model. The read, write, and validation activities for posting the posting documents run as follows:

1. When the documents are created from the payroll results, data from the master data and from Customizing for Accounting is read synchronously to Accounting using BAPIs.
2. When posting is triggered, the following occurs:
 - a. The document data is checked against the Accounting data either locally or remotely using synchronous BAPIs.
 - b. Each document is transferred asynchronously to the Accounting system using the ALE layer.
3. The data is posted to Accounting.

Prerequisites

The following tables in the AC system must be replicated in the HR system.

- *Table of Document Types* (T003)
- *Table of Line Item Texts* (T053)

In ALE Customizing, you must specify the objects and methods that run in a different accounting system (under *Basis* → *Application Link Enabling (ALE)* → *Modelling and Implementing Business Processes* → [Maintain Distribution Model and Distribute Views \[Extern\]](#)).

Posting Payroll Posting Documents

For a list of objects and methods as well as information on the procedures, see Customizing for *Cross-Application Components* under *Predefined ALE Processes* → *Human Resources* → *HR* <-> *AC* → *Posting Payroll Results to Accounting* → [Set Up 'HR and Accounting from Release 4.0A' Scenario \[Extern\]](#).

Wage and Salary Payments

Use

In this ALE business process, you create the payment medium for wage and salary payments to your employees. In some cases, you can also create payments to third-parties. Since data which is also used for wage and salary payments is of a particularly confidential nature, no data is transferred to a separate financial accounting system in this business process. This procedure is also recommended since wages and salary payments are normally processed by employees in the Personnel department.

Integration

Although financial accounting programs are also used in this ALE business process, all programs involved are run in the HR system. The data is stored and evaluated in the HR system. There is no flow of data between the systems.

Data Flow

Process flow for wage and salary payments

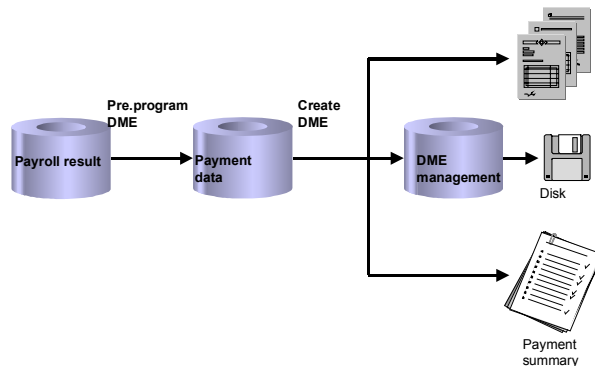

The *Pre.program DME* reads the relevant data from the payroll result, creates the payment data and stores it in the database. The payment medium program processes this payment data and creates the corresponding payment medium.

Process flow for wage and salary payment by check with integrated remuneration statement

Wage and Salary Payments

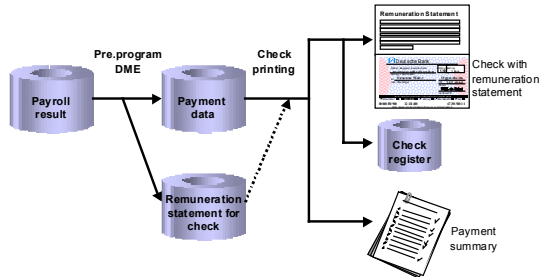

In some countries, it is possible to print checks with an integrated remuneration statement for your employees. This means the remuneration statement is printed on the check. With this function, the remuneration statement is generated by the *Pre.program DME* and saved on the database. The check printing program reads the remuneration statement from the database and prints it on the check. An entry is created in the check register for each check.

Prerequisites

To be able to process the payment data locally in the HR system, Customizing for HR and FI must be set up accordingly. Even though these Customizing settings belong to FI, you must still make the settings for this business process in the HR system since the payment data is processed locally in the HR system, and the required Customizing settings cannot be read over systems.

HR Customizing:

- Determine paying company codes
- Determine the house bank
- Determine the house bank account

You make these settings in Customizing for Payroll under Data Medium Exchange → *Preliminary Programs for Data Medium Exchange*.

FI Customizing:

- Set up bank master data
- Set up house bank
- Set up house bank account
- Set up payment methods

To make these settings, choose Customizing for Financial Accounting under *Accounts Receivable and Accounts Payable* → *Business Transactions* → *Automatic Outgoing Payments*. You use the above path to set up the house bank and house bank account in HR Customizing.

Activity Allocation in Training and Event Management

Use

The interface *Activity Allocation in Training and Event Management* lets you settle attendance fees and instructor functions for internal employees from *Training and Event Management* in a central *Controlling System (CO)*.

This business process can be implemented in the following variants:

- [Activity Allocation in Training and Events: Attendance Fees \[Extern\]](#)
- [Activity Allocation in Training and Events: Instructor Function \[Extern\]](#)

Cost Transfer Posting in Training and Event Management

Cost Transfer Posting in Training and Event Management

Use

The interface *Cost Transfer Posting in Training and Event Management* lets you transfer business event costs from the *Training and Event Management* component to a *Cost Accounting* system (CO).

Integration

Functions in Training and Event Management

- Determine business event costs
- Determine cost items to be transferred
- Transmit cost transfer data to CO
- Create a reference number for cost transfer posting
- Compare documents, that is, check the transfer posting
- Cancel document

Functions in Cost Accounting

- Check completeness of data transmitted from *Training and Event Management*
- Transfer posting of cost items of business events
- Transmit document information for document comparison with *Training and Event Management*

Cost Transfer Posting in Training and Event Management

Data Flow

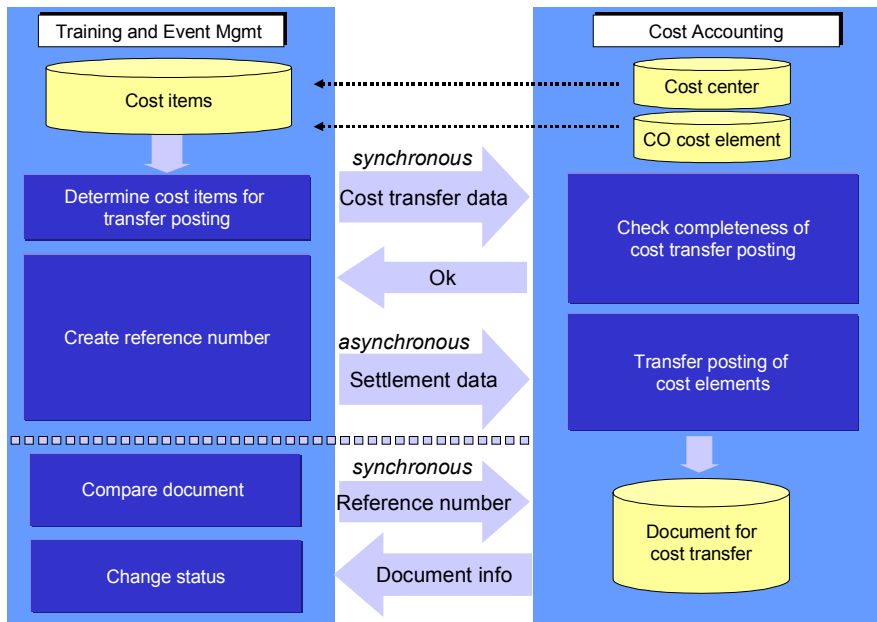

- In *Training and Event Management (TEM)*, the report **RHCCOS00** is used to determine what cost items have to be transferred. Settlement data is transmitted to *Cost Accounting (CO)*. A completeness check is carried out for the data. This data transfer is realized using synchronous communication.
- If the result of the check is positive, a reference number is created in *Training and Event Management* and the settlement data is transferred to *Cost Accounting* via asynchronous communication.
- In *Cost Accounting*, the transfer posting is performed for the cost items. This generates a document.
- A document comparison is performed in *Training and Event Management* whereby the reference number is transmitted to *Cost Accounting*. The document information is returned to TEM from CO (using synchronous communication).

Prerequisites

- Cost centers and CO cost elements must be distributed.
- The customer distribution model must be maintained. When you are specifying the object method, you must define the HR system as the sending system and the CO system as the receiving system.

The following entries must be made in ALE Customizing in the step [Maintain Distribution Model and Distribute Views \[Extern\]](#) under *Maintain method*:

CLIENT: HR System

SERVER: CO System

Cost Transfer Posting in Training and Event Management

OBJECT: AcctngRepostPrimaryCosts

METHOD: Post

OBJECT: AcctngRepostPrimaryCosts

METHOD: Check

OBJECT: ControllingDocument

METHOD: FindDetails

You can generate the [partner profile \[Extern\]](#) from the distribution model. For more information, refer to the ALE-IMG under [Generate Partner Profile \[Extern\]](#).



You can find more information on the ALE business process *Cost Transfer Posting in Training and Event Management* in the IMG under [Set Cost Transfer Posting in Training and Event Management \[Extern\]](#).

See also:

[Business Process Flow of Cost Transfer Posting in Training and Event Management \[Extern\]](#)

Amounts Withheld from Suppliers as Taxes (Spain)

Use

This interface provides HR with data from *Financial Accounting* (FI) regarding taxes to withhold from suppliers. FI handles the relevant tax data, transfers it using this interface to HR which produces the legal forms containing the data. This interface is only relevant for Spain.

Integration

The interface is realized using a function module.

Create Vendor Accounts from HR Master Record

Create Vendor Accounts from HR Master Record

Use

In the *Travel Management* application component, which is assigned to *Financial Accounting* (FI), personnel numbers are used to pay business trip costs into vendor accounts. To pay business trip costs, you require an appropriate vendor account in FI.

HR master data must be replicated in the FI System using ALE. The *Create Vendor Accounts from HR Master Record* interface enables you to transfer HR master data to the FI System. After the data has been transferred, a program runs in the FI System that uses the HR data to create the appropriate vendor accounts. Once these vendor accounts have been created, the FI System can pay the trip costs.

Integration

The *Create Vendor Accounts from HR Master Record* interface is supported by ALE. You must replicate the following infotypes:

- 0000 Actions
- 0001 Organizational Assignment
- 0002 Personal Data
- 0003 Payroll Status
- 0006 Addresses
- 0009 Bank Details
- 0017 Travel Privileges

Activities

Call up the R/3 library and see *CA - Cross-Application Components* → *ALE Business Process Library*.

VAT Indicators in HR Travel Customizing

Use

This is a technical interface. In Customizing of the *Travel Management* application component, you must enter default VAT indicators. To check if VAT indicators are correct, you need text describing the VAT indicators. A function module reads these texts from *Financial Accounting* (FI) and transfers the data to HR.

Integration

This interface is ALE-enabled. Customizing data T706A and T706S are replicated locally in the HR system.

Human Resources <-> External Applications

Human Resources <-> External Applications

This section contains details of ALE business processes between R/3 Human Resources Components and external application components.

Process Flow: Import Payroll Results from a Third-Party System

Purpose

If you run payroll in an external system, you use the data import method shown here in the R/3 System.

Prerequisites

You have set up the ALE distribution model in Customizing.

Process Flow

Importing Data to the R/3 Payroll System

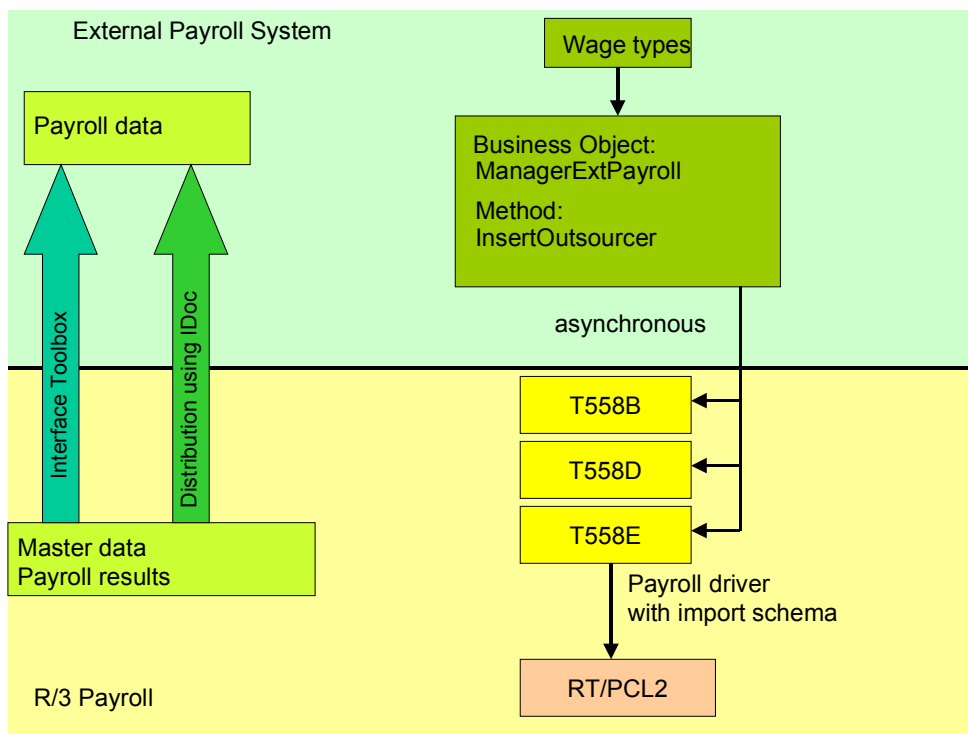

- An IDoc is created for each employee from the input file containing the wage types from the external payroll system. The *InsertOutsource* BAPI is called for each IDoc. Due to the amount of data, we recommend that you call the BAPI asynchronously. This also applies if you use your own file interface.

For documentation on the BAPI and its interfaces, see the BAPI Explorer.

- The BAPI creates entries in the following interface tables:

Payroll Account Transfer: Payroll Periods (T558B)

Transfer Wage Types with Split Indicator (T558B)

Transfer External Payroll-Arrears Results – International (T558E)

Process Flow: Import Payroll Results from a Third-Party System

For performance reasons, these tables are only updated once per input file.

Before the data is transferred to the tables, the system deletes the existing entries for the respective personnel numbers. The *Start date* (BEGDA) and *End date* (ENDDA) fields are filled with the end date of the current payroll period.

- The payroll driver must be started with a special import schema which writes the data from the interface tables to the payroll results in PCL2. SAP provides schema *XINF* as an example.



To create an example for an input file, you can use report RPUOUTIDOC. This report creates IDocs from the entries in tables T558B, T558D, and T558I. You can write to a file interface using the IDoc exit.

SAP recommends this method. Other methods for data import:

- You write a report that calls the BAPI *InsertOutsourcer* asynchronously. The BAPI is called for each personnel number and reads the data in the interface tables. In this case, you should regularly execute the command COMMIT WORK by calling the *BAPIService.TransactionCommit* BAPI. The data in the interface tables is then updated with the data from the working memory.
- A separate report is used to fill tables T558B, T558D, and T558E.

Accounting

This section contains details of ALE business processes between R/3 Accounting Components and other R/3 Components.

Distributing Master Data

Distributing Master Data

This section describes how master data is distributed in Accounting.

Work Breakdown Structure or Internal Order Distribution

Use

To carry out actual postings in distributed systems for internal orders and work breakdown structures, you can distribute the master data and status information of internal orders and work breakdown structures to more than one system.

Integration

Functions in the Master System

All functions for internal orders and work breakdown structures are available. However, in the master system you cannot call up the corresponding line items from line item reports if the line items all come from one receiving system.

You create the internal orders or the work breakdown structures in the master system. When you save them, the R/3 System distributes them automatically to one or more receiving systems. Through the filter objects Controlling area and order type or project profile, you control whether, and in which system, the internal orders or work breakdown structures are to be distributed.

You can also send released internal orders and work breakdown structures at a later date.

Functions in the Receiving System

- Master data and status information display
You can only make changes in the original master system. These changes are transferred to the receiving systems.
- Postings from other R/3 components (such as, FI, MM)
- Assessment
- Distribution
- Periodic reposting
- Manual reposting (costs, revenues, line items)
- Direct and indirect activity allocation
- Reposting internal activity allocation
- Accrual calculation
- Settlement debits
- Line item reports

Restrictions with Distributing Internal Orders and Work Breakdown Structures

- WBS elements cannot be distributed individually. Only complete work breakdown structures are distributed.
- If a WBS element is assigned to an internal order, the system does not automatically distribute this WBS element to the receiving system. This means that the assignment of the WBS element to the internal order is not known in the receiving system.

Work Breakdown Structure or Internal Order Distribution

If required, you can distribute the work breakdown structure first to the receiving system and then later on distribute the internal order.

- If you settle activities of cost centers that do not exist in the master system, you can only settle the internal order or work breakdown structure using settlement type FUL.

The following business transactions are not possible in the receiving system:

- Planning of internal orders, costs, and appointments on work breakdown structures
- Budgeting and availability control
- Commitment postings
- Overhead costing
- Settlement of internal orders and WBS elements
- Assignments of orders and networks to the work breakdown structure



If you set the deletion indicator in the master system for an internal order or a work breakdown structure and this change was adopted in the receiving system, the R/3 System also deletes the given internal order or work breakdown structure in the receiving system. To ensure that in the receiving system you cannot make postings to deleted objects, you should choose a time period corresponding to the setting of the deletion flag and the setting of the deletion indicator (for example, for internal orders by setting residence time 1). You must make sure that the *Deletion flag* status has been adopted in all receiving systems **before** you set the deletion indicator in the master system.

Data Flow

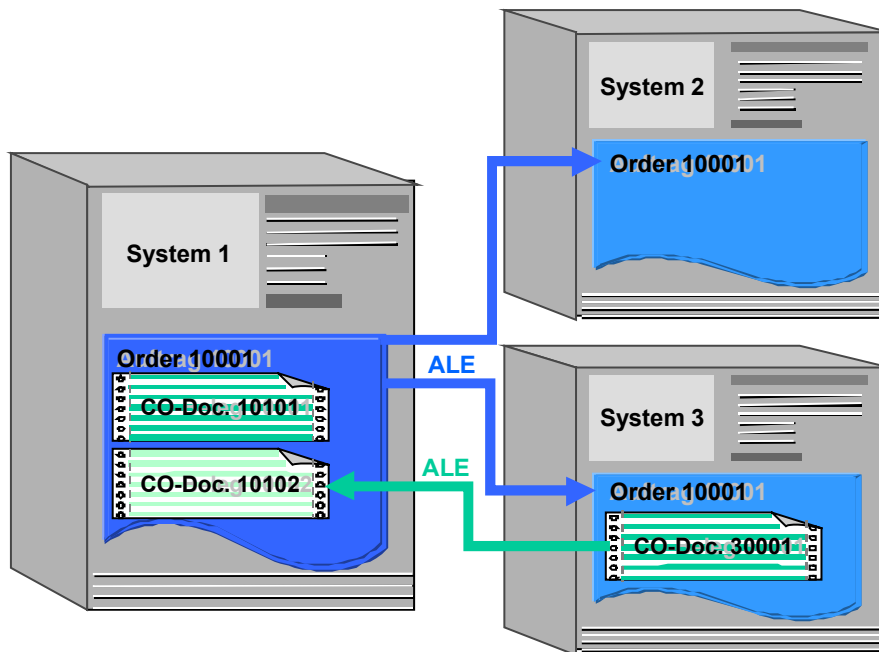

The data flow between distributed systems is identical for internal orders and work breakdown structures. This is described using the example of an internal order:

If you create or change internal order 10001 in system 1, it is automatically distributed to the receiving systems (in this case: system 2, system 3) and created or changed there using the same order number. System 1 is the master system of internal order 10001.

- Postings made in the master system are only available in the master system (CO document 10101 in this case).
- Postings made in other receiving system (in this case, system 3) are sent via ALE to the master system. They are available in the both the receiving system and in the master system (in this case, CO doc. 30001 from system 3 is given its own number CO doc. 10102 in the master system).

Prerequisites



Whenever possible, you should carry out all cross-system Customizing settings in **one** system.

- The **organizational units** (e.g. controlling area, company code) are defined **identically** in the master system and the receiving systems.
- The **order type** or the **project profile** are defined **identically** in the master system and in the receiving systems.
- The **status selection profiles** are defined **identically** in the master system and in the receiving system.

Work Breakdown Structure or Internal Order Distribution

- For internal orders: The **number ranges** are defined **separately** in the master system and in the receiving system. This is because a distributed internal order in the receiving system is given the same number as in the master system.

or work breakdown structures: The **project edit screens** are defined **identically** in the master system and in the receiving systems. In the receiving systems you should include a lock indicator for the project edit screens, so that these project numbers cannot be used for new projects.

Activities

In the Implementation Guide (IMG), choose *Basis Components* → *Distribution (ALE)* → *Predefined ALE Business Processes* → *Accounting* → *Master Data Distribution* → [Distribution of Internal Orders \[Extern\]](#) or [Distribution of Work Breakdown Structure \[Extern\]](#).

Use the following objects:

Business object	<i>Work Breakdown Structure</i>	<i>Internal Order</i>
Distribution method	<i>SaveReplica</i>	<i>SaveReplica</i>
Message type		<i>INTERNAL_ORDER</i>

To send internal orders and work breakdown structures at a later time, choose *Tools* → *ALE* → *Master data distribution* → *Accounting* → *Internal Order* or *Projects* → *Send*.

For more information about *ALE* see the SAP Library under *Basis* → *Middleware* → *ALE-Introduction and Administration*.

Accounting <-> Accounting

This section contains details of ALE business processes between R/3 Accounting Components.

The Reconciliation Ledger and ALE

The Reconciliation Ledger and ALE

Use

Using the [Reconciliation Ledger \[Extern\]](#) you can reconcile controlling data with financial accounting data when you are using a distributed, yet integrated SAP R/3 installation. In cross-company-code transactions, [Reconciliation Postings \[Extern\]](#) between the [Company Codes \[Extern\]](#) are created in financial accounting.

Integration

Distribution in Central Cost Center Accounting

IDoc To Be Sent (Message Type)	Name	Central → Decentral	Decentral → Central
RCLROL	Reconciliation Ledger		X

Distribution in Decentralized Cost Center Accounting

IDoc To Be Sent (Message Type)	Name	Central → Decentral	Decentral → Central	Decentral → Decentral
RCLROL	Reconciliation Ledger		X	

Process Flow

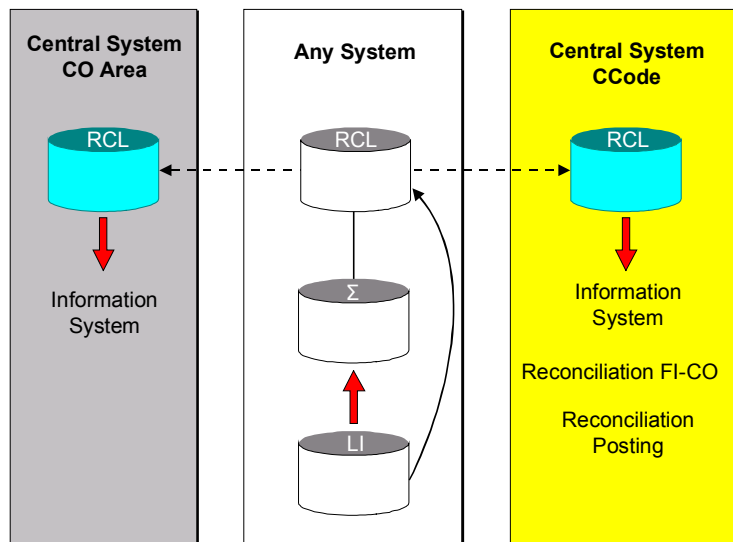

RCL = Reconciliation Ledger Totals Records
 Σ = Totals Records
 LI = Line Items

Totals records for CO objects update in the reconciliation ledger. In Controlling, the ledger supplies data for the information system. In cross-company-code transactions, the reconciliation

The Reconciliation Ledger and ALE

ledger information helps create reconciliation postings between the corresponding company codes in FI.

The reconciliation ledger is updated for all CO objects (for example, [Cost Centers \[Extern\]](#), [Orders \[Extern\]](#)) that have transaction data in this system. Distribution method 1 updates cost center entries only in the central cost accounting system, whereas method 2 updates only in the master system of the cost center.

The contents of the reconciliation ledger is periodically sent to the central cost accounting system. If central financial accounting uses a different system than cost center accounting, the reconciliation ledger is also sent to central financial accounting. You can make reconciliation postings only in the company code local system.



For more information about ALE see the SAP Library under *Basis* → *Middleware* → *ALE-Introduction and Administration*.

Financial Accounting (FI-GL)

Financial Accounting (FI-GL)

For each company code there is a central R/3 or R/2 System that receives the transaction data from one or more decentral systems. The scenario is designed to allow general ledgers to be linked and to allow a separation to be made between the general ledger and the subsidiary ledger.

Reference Model for Distributed Financial Accounting

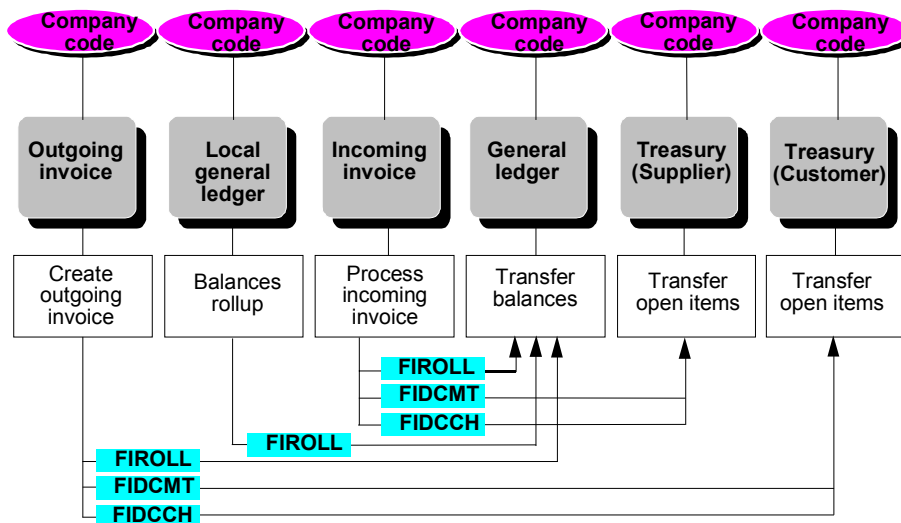

You can use either of the following options for transferring account information from the local financial accounting to the central R/3 System:

- Every line item that is booked to the decentral account gets sent to the central system separately.
- The delta for the transaction data is sent to the central system periodically (usually at the end of each accounting period), using the rollup technique from the Special Purpose Ledger module.

There is an “external accounting” flag in the G/L account master record that determines which of these two options should be used. If the flag is set, then individual line items are sent. If the flag is not set, then the transaction data deltas are sent. For a subsidiary ledger the method used is determined by the flag belonging to the corresponding reconciliation account.

This allows the communication between systems to be kept to a minimum, since most accounts are not sent as line items. On the other hand, it also guarantees that the transaction data for all the general ledger accounts are sent to the central system.

A table-controlled conversion can be performed on the G/L accounts of the decentral system to the G/L accounts on the central general ledger before the data is sent. This is useful if the charts of accounts in the central system are different from those in the decentral system.

A clearing account is kept for each decentral system in the central financial accounting. This is needed because a decentral system does not send complete documents but only selected

Financial Accounting (FI-GL)

document lines that may show a balance. In that case the balance from the input document lines is offset on the clearing account to obtain a cleared document. The clearing account has to be cleared at the period-end, if all the data from the distributed system has been transferred.

Example of Distributed Financial Accounting

In order to illustrate the processes in a distributed financial accounting scenario, we will now look at the interaction between a decentral logistics system (in this example, purchasing) and a central financial accounting system.

The Distribution Logistics - Financial Accounting

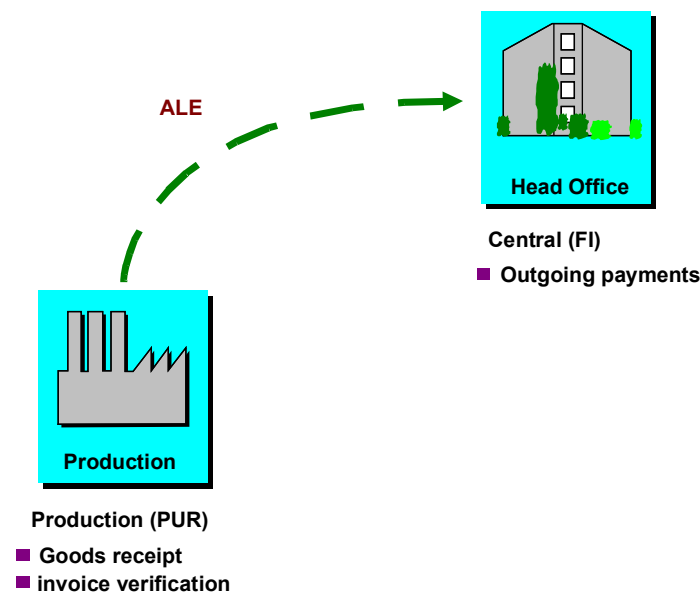

As mentioned above, this coupling is performed in the distribution for financial accounting.

The assumption is made that the charts of accounts in the two systems are the same. The reconciliation account for the vendors is the only one in the logistics system for which the “external accounting” flag is set. This causes every open item that is posted to a vendor to be sent to the central system. Payment is made here.

The following transactions will be looked at:

- Receipt of materials from an external vendor
- Receipt of the invoice for this transaction
- Goods issue for consumption
- Payment to the vendor

Each of these transactions is assigned a sequence number.

Financial Accounting (FI-GL)

Postings in the Logistics System

A goods receipt with a value of \$1,000 is posted (1). This is followed by the receipt of an invoice for \$1,150 including sales tax (2). Finally there are goods issues (outward movements of goods) in the logistics system as consumption (4-6).

Goods Receipt

Activity	Debit account	Debit amount		Credit account	Credit amount
(1)	Stock	\$1000	to	Goods/invoice rcvd. (clearing account)	\$10000

Invoice Receipt

Transaction	Debit account	Debit amount		Credit account	Credit amount
(2)	Sales tax	\$150	t o	Vendor	\$1150
	Goods/invoice rcvd.	\$1000			

Goods Issues

Transaction	Debit account	Debit amount		Credit account	Credit amount
(4)	Consumption	\$100	to	Stock	\$100
(5)	Consumption	\$200	to	Stock	\$200
(6)	Consumption	\$300	to	Stock	\$300

Postings in the Central Financial Accounting

The open item for the vendor is copied to the central financial accounting system, the payment is made there and the transaction data is copied there from the decentral R/3 System (3).

Transaction	Debit account	Debit amount		Credit account	Credit amount
(3)	Clearing account	\$1150	t o	Vendor	\$1150

The transaction data is also periodically copied to the central R/3 System (7):

Financial Accounting (FI-GL)

Transaction	Debit account	Debit amount		Credit account	Credit amount
(7)	Goods/invoice rcvd.	Stock	t o	Goods/invoice rcvd.	\$1000
	Sales tax	\$150		Stock	\$600
	Stock	\$1000		Clearing account	\$1150
	Consumption	\$600			

A payment is made to the bank:

(8)	Vendor	\$1150	to	Bank	\$1150
-----	--------	--------	----	------	--------

<u>Logistics R/3 System</u>	<u>Central Financial Accounting</u>		<u>Goods/invoice rcvd.</u>	
(2) \$1000	(1) \$1000		(7) 1000	(7) \$1000

<u>Sales tax</u>		<u>Sales tax</u>	
(2) 150		(7) \$150	

<u>Stock</u>		<u>Stock</u>	
(1) \$1000	(4) \$100	(7) \$1000	(7) \$600
	(5) \$200		
	(6) \$300		

<u>Expense</u>		<u>Consumption</u>	
(4) \$100		(7) \$600	
(5) \$200			
(6) \$300			

<u>Vendor</u>		<u>Vendor</u>	
	(2) \$1150	(8) \$1150	(3) \$1150

Financial Accounting (FI-GL)

			Bank	
				(8) \$1150

			Clearing	Logist. System 1
			(3) \$1150	(7) \$1150

Currently no transaction data is sent from the central system to the decentral system, and in particular no information is sent concerning the outgoing payment to the vendor that was posted in the central system.



Because the open item for the vendor was sent to the central financial accounting, it is marked as cleared in the decentral system. This ensures that payment can be made only from the central system and no double payment (i.e. central and decentral) can be made. The “open” item in the decentral system is reorganized as part of the FI document reorganization run.

No confirmation of the payment information is sent from the central system to the decentral system.

Sending Document Changes

How the decentral system handles document changes mainly depends on whether the document line was sent as a line item or is relevant to rollup. There are no restrictions on rollup-relevant document lines since this kind of document line is not known to the central system in detail. These lines can be changed and no messages are sent.

Document lines that were sent as line items can be changed later using certain Logistics transactions only. Changes can no longer be made in the decentral financial accounting, since the central system has the accounting responsibility for these document lines. In the Logistics system changes can only be made from the invoice verification (purchasing) and the billing (sales). These changes are sent to the central R/3 System using the FIDCCH (FI nancial DoCument CHange) message type.



The invoice verification posts an incoming invoice, for which there has not yet been a goods receipt. A logistical payment block is applied to the open item for the vendor in the associated FI document and the item is sent to the central system with the FIDCMT message. After the goods arrive, the purchasing department releases the invoice by removing the logistical payment block in the document line for the vendor. This change is sent to the central system using the FIDCCH message. Payment is then made from there through the payment program.

In a similar way, changes to the dunning block or to the reference document number are sent from sales to the central system using the FIDCCH message.

Master Data to be Distributed

- G/L accounts
- Customers
- Vendors

Control Data to be Distributed

The control data that has to be distributed for the scenario is described in the ALE Implementation Guide.

Constraints

Central cash management and forecast are not supported.

No group cash concentration, i.e. decentral payment proposals are sent to the central system and are collected together and paid there.

In central R/2 real-time financial accounting, tax accounts cannot be copied using line items.

Cross-system advance returns for sales and purchase tax are not supported.

Cross-system credit management is not supported.

Transaction data flows from the decentral R/3 System to the central R/3 System only and never in the other direction.

Special G/L transactions (for example, down payments on purchase orders, for example) are not supported in a distributed environment.

Only relevant data is sent to the G/L. Account. Assignments to CO objects, for example, to a cost center, are not included in the IDoc. The message type CODCMT is used to send CO relevant data (see CO scenario).

Special Purpose Ledger (FI-SL)

Special Purpose Ledger (FI-SL)

Using ALE you can send the data contents of ledgers from one or more decentralized systems to a central system. Data can be transferred either at the same level of detail or in summarized form.

Distribution in the Special Purpose Ledger can also be used if accounting data is required in the central system but is not sent from the local system to the central system in the standard.

In this case you need to define a ledger in the Special Purpose Ledger with the required data fields and then specify that it should be sent to the central system.

The ledger distribution uses the rollup technique in Special Purpose Ledger. You can start a periodic rollup that sends the delta of the ledger data since the last rollup to all interested systems.

Reference Model for Special Purpose Ledger

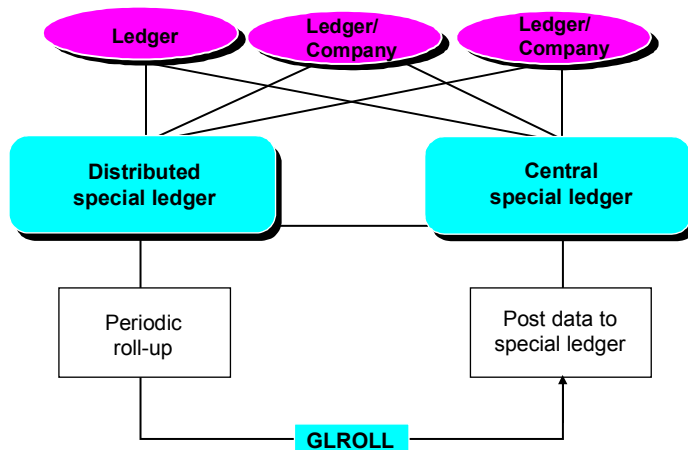

ALE/Distribution in Product Cost Planning

Use

You can use the ALE functions in **Product Cost Planning** to distribute the cost component split as follows:

- To Profitability Analysis and to Sales and Distribution, if they are operated in separate systems ([Distribution to Profitability Analysis and Sales and Distribution \[Seite 96\]](#))
- In group costing, to supply information about the product costs of separate production planning systems to a central cost accounting system ([Group Costing in Distributed Systems \[Seite 98\]](#))
- To transfer the costing results to other systems, for further costing to be carried out ([Further Costing in Other Systems \[Seite 101\]](#))

Prerequisites

To set up a distribution of business processes and functions with ALE, you must create a **logical distribution model** for the entire system. In the model, you determine which applications run on which systems, and which messages exchange applications with each other. The distribution model thus describes the ALE message flow between logical systems. You specify which master data and transaction data is to be exchanged, and which control data should be recognized by the distributed systems. You also determine in the distribution model the systems to which costing data should be sent.

For further information about the procedure for preparing and creating the models for distribution, see the SAP Library under [ALE - Introduction and Overview \[Extern\]](#) and in the Implementation Guide under *Cross-Application Components → Distribution (ALE)*.

You must maintain the corresponding **master data and control data** in [Customizing for ALE \[Extern\]](#). Customizing of the sending system must be available in the target system.

- There is a model plant.
 - The plant in the sending system to which the cost component split should be distributed exists in the target system as the model plant (or also as the shadow plant). The cost component split is distributed to this plant in the target system.
- The costing variant is available with all Customizing parameters.
- Customizing of the cost component structures used was distributed to a Customizing master system.

The material masters must exist in the target system, with accounting and costing views. For more information, see the following sections in the SAP Library:

- [Distribution of Master Data \[Extern\]](#)
- [Example of Master Data Distribution \[Extern\]](#)

Features

The costing data can be distributed to particular systems or to all the logical systems that are specified in the distribution model as recipients of costing data. If you do not make any entries for

ALE/Distribution in Product Cost Planning

the target system, the data is distributed to all the systems specified in the distribution model as recipients of costing data.

You can access these functions by choosing *Accounting* → *Controlling* → *Product Cost Planning* → *Tools* → *Material Costing* → *Distribution* → *Cost Component Split*.

You can select the **costing data to be distributed** using the material number, class (of a group of materials), plant, costing variant, costing version, costing status and validity of the cost estimate. The selected data is picked out by the system, and transferred in IDocs.

You can choose whether

- additive cost estimates
- automatic (i.e. non-manual) cost estimates (that is, cost estimates without quantity structure)
- current standard cost estimates

should be transferred. If you do not make any entries, no cost estimates will be distributed.



In the sending system, released standard cost estimates are not automatically released in the receiving system. Marking standard is *allowed*. For more information, see [Updating Standard Prices \[Extern\]](#).

To work with **classes**, assign the materials in question to a class. Choose *Logistics* → *Central functions* → *Classification* → *Allocation* → *Maintain* → *Objects to class*.

You can also use the following ALE functions:

- Filters:

Filters are conditions that must be met by message types and BAPIs so that they can be distributed via ALE. Here, you can specify that only materials shall be sent that have been assigned to a particular class as defined in Customizing. The materials in the class can be maintained as above.

- Reference:

You can specify that, in addition to the filter objects of message type COPCPA, filter objects from a message type of the material (such as MATMAS) can be sent to the application. In other words, only those material cost estimates can be distributed for which the material can also be sent.

You activate both functions in the distribution model in Customizing. For the filter function, you also assign the corresponding class to a logical system.

See also:

- [ALE Integration Technology \[Extern\]](#)
- [ALE and the R/3 Procedure Model \[Extern\]](#)
- [Technical Requirements for ALE Business Processes \[Extern\]](#)
- [Distribution of Control Data \[Extern\]](#)
- [Distribution of Master Data \[Extern\]](#)
- [Message Exchange \[Extern\]](#)
- [Modeling Distribution \[Extern\]](#)

- [Distribution Model \[Extern\]](#)
- [IDocs \[Extern\]](#)
- [Classes \[Extern\]](#)
- [Filters \[Extern\]](#)

Distribution to Profitability Analysis and Sales and Distribution

Use

If you carry out Profitability Analysis based on costing data from another R/3 system, the data must be exchanged between both systems. The costing results can then be analyzed in the form of a cost component split in Profitability Analysis.

If costing data from another R/3 system is to be accessed by Sales and Distribution, the data must be exchanged between both systems. The costing results can then be used in Sales and Distribution.

Features

Data Flow:

Distribution of the Cost Component Split to Profitability Analysis and Sales and Distribution (I)

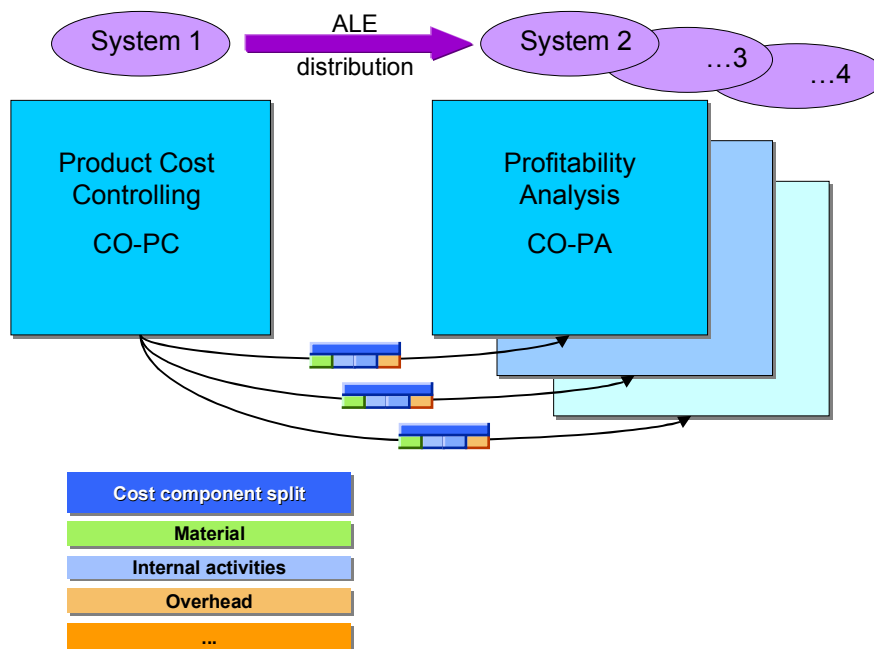

The results of a cost estimate (the cost component split) can be distributed to a particular system or to all the logical systems that are defined in the **customer model** to receive the costing data.

You distribute the cost component split by choosing *Accounting* → *Controlling* → *Product Cost Planning* → *Tools* → *Material Costing* → *Distribution* → *Cost Component Split*.

The system transfers the data into IDocs. If you do not enter a target system, the cost estimates selected for distribution are sent to all the receivers defined in the distribution model.

Data Flow:

Distribution to Profitability Analysis and Sales and Distribution

Distribution of the Cost Component Split to Profitability Analysis and Sales and Distribution (II)

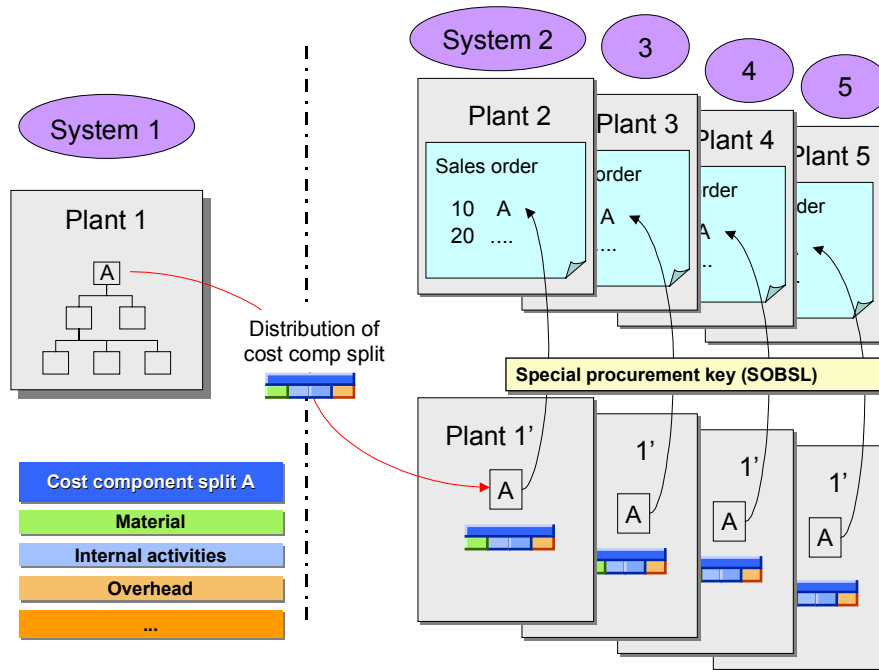

Material A is costed in **Plant 1** (System 1). The cost component split for Material A is distributed by ALE to System 2 (mirror plant 1') and to other systems, if applicable. The cost component split can now be used in System 2 by Profitability Analysis and Sales and Distribution for analysis or for price determination when billing documents are created. In the receiving system, the material must be recosted, in which the cost component split of Material A in plant 1' is accessed by special procurement keys.

See also:

You can find further information about the analysis and further use of standard cost estimates in Profitability Analysis and Sales and Distribution in the R/3 Library under the following:

[Components for Profitability Accounting \[Extern\]](#)

- [Valuation \[Extern\]](#)
- [Valuation using Material Costing \[Extern\]](#)

[Sales and Distribution: Pricing and Conditions \[Extern\]](#)

Group Costing in Distributed Systems

Group Costing in Distributed Systems

Use

You can use the ALE functions to send [cost component splits \[Extern\]](#) from local systems to a central system, and create a [group cost estimate \[Extern\]](#) centrally (less any transfer prices).

Features

You can use the ALE functions in **Product Cost Planning** to supply information about the product costs of separate production planning systems to a central cost accounting system. ALE supports the sending of information about value-added portions.

Data Flow: Distribution of the Value Added to a Central Cost Accounting System

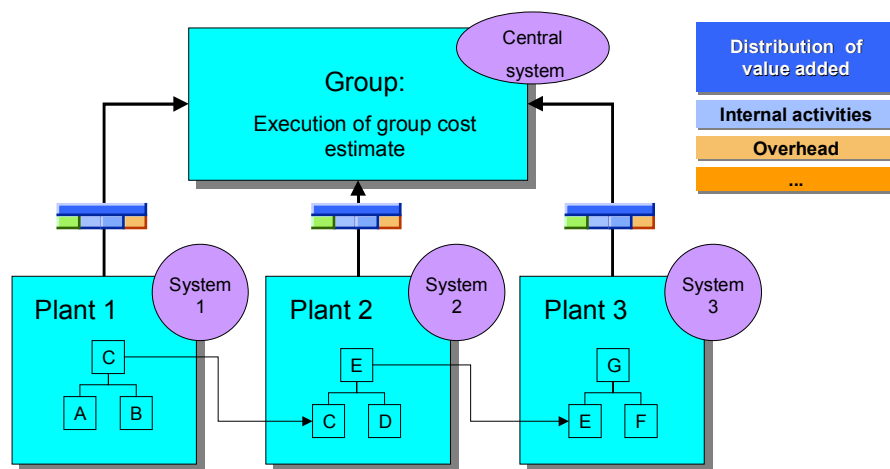

First, cost estimates that are independent of each other are created in every plant and system where the materials are to be produced. If you want to create a group cost estimate in a central system, you must send the costing results (cost component split) from every local plant to the central system. You can use ALE for this.

If a plant receives a material from another plant, the price paid to the supplying plant may be a transfer price. However, a group cost estimate does not contain transfer prices and reflects only those costs arising in the group itself.

Because of this, you can only distribute the value-added portions from the local systems to the central system. You must therefore calculate the value added in the local systems for the materials to be sent to the central system. You can access these functions by choosing *Accounting* → *Controlling* → *Product Cost Planning* → *Tools* → *Material Costing* → *Determine value added*. By entering certain selection criteria, you can choose the cost estimates whose value added is to be sent to the central system. The value-added portions are transferred by the system in the form of an [additive cost component split \[Extern\]](#).

You can now send the additive cost component split by ALE to the central cost accounting system. There, you can create a group cost estimate, minus any [transfer prices \[Extern\]](#). A prerequisite is that material masters and BOMs have also been distributed and exist in the target system.

Group Costing in Distributed Systems



For the purposes of group costing, the value added should not be recosted. This means that instead of reselecting routings, work centers, cost centers, activity prices and such, the value added portions distributed to the central system should be transferred. You achieve this by making **no** entries for routing selection in the quantity structure control in Customizing.

Please ensure that you have specified in the valuation and costing variants additive costs are to be included in costing.



You produce and cost the following in three decentralized plants and systems:

- Plant 1, system 1: material C, consisting of materials A and B
- Plant 2, system 2: material E, consisting of materials C (from plant 1) and D
- Plant 3, system 3: material G, consisting of materials E (from plant 2) and F

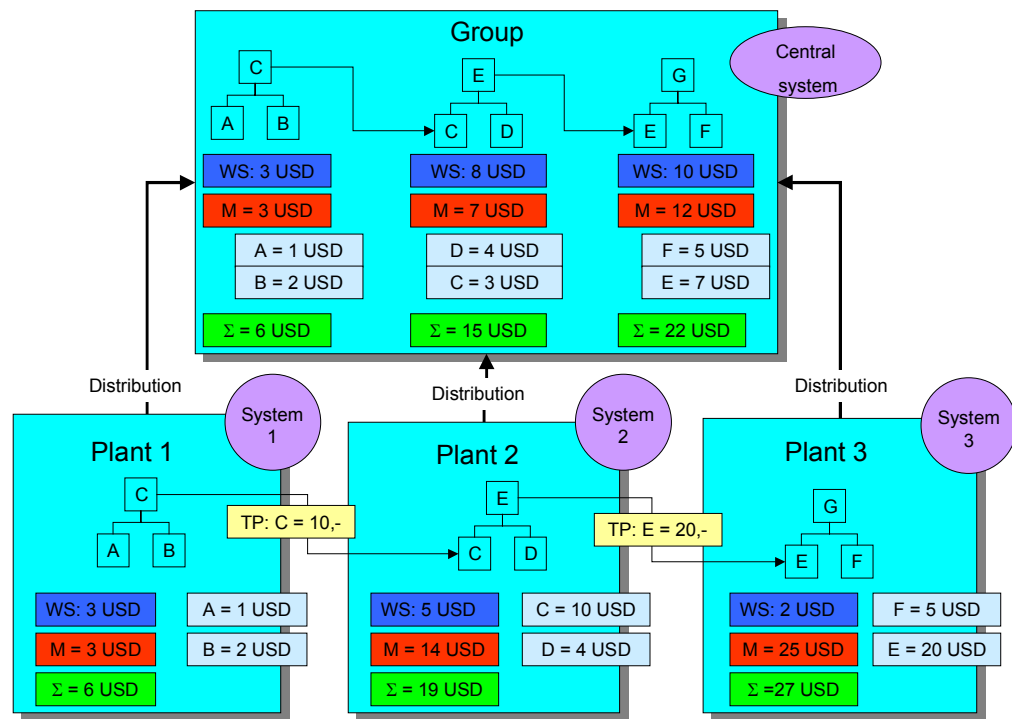

You create a cost estimate for the material produced in each plant:

Group Costing in Distributed Systems

Plant 1 / System 1	Plant 2 / System 2	Plant 3 / System 3
A = 1 USD	C = 10 USD	E = 20 USD
B = 2 USD	D = 4 USD	F = 5 USD
Σ Mat. = 3 USD	Σ Mat. = 14 USD	Σ Mat. = 25 USD
WS = 3 USD	WS = 5 USD	WS = 2 USD
Σ C = 6 USD	Σ E = 19 USD	Σ G = 27 USD

- The costs for producing **material C** in plant 1 are **USD 6**. The material is sold to plant 2 for USD 10 (transfer price).
- The costs for producing **material E** in plant 2 are **USD 19**. The material is sold to plant 3 for USD 20 (transfer price).
- The costs for producing **material G** in plant 3 are **USD 27**.

You now calculate the value added in plants 1 to 3, and send it to the central system. Here, you create a cost estimate without the transfer prices, containing the value added distributed to the central system. A prerequisite is that material masters and BOMs for materials A to G have also been distributed and exist in the target system.

The costs for the manufacture of **material G** are **USD 22**.

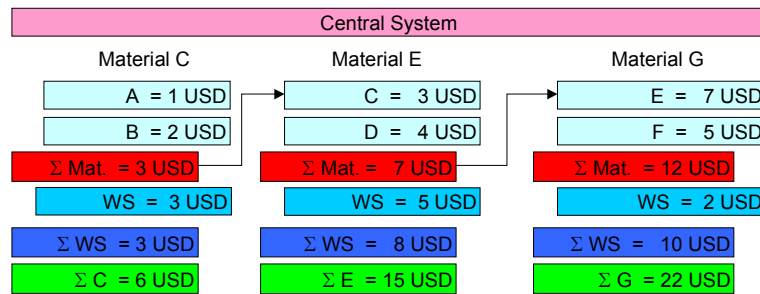

Further Costing in Other Systems

Use

You can use the ALE functions in Product Cost Planning to transfer the costing results into other systems for further costing purposes.

The results of a cost estimate (cost component split) can be distributed to a particular system or to all the logical systems that are required in the customer model to receive the costing data.

Features

Data Flow: Further Costing in Other Systems

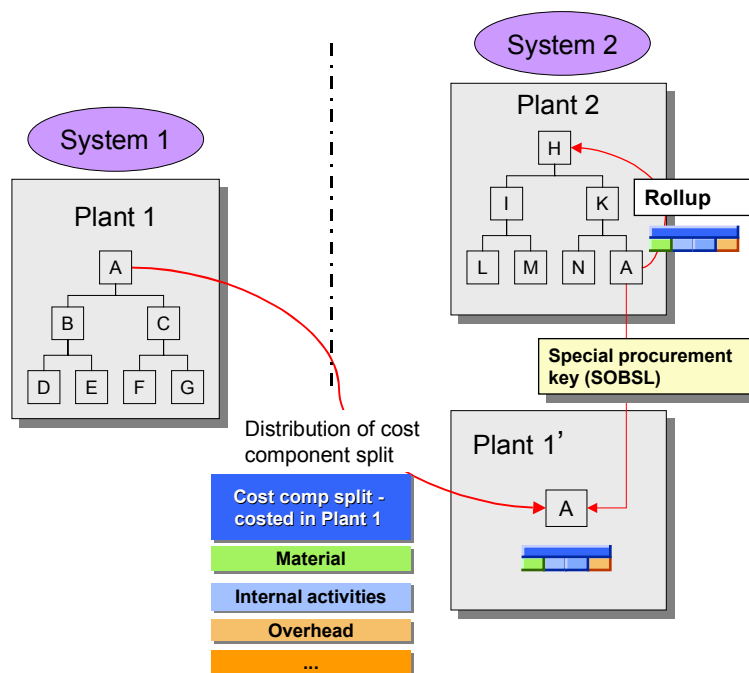

Material A is costed in **Plant 1** (System 1). The cost component split for Material A is distributed by ALE from System 1 to System 2, and is used for further costing for Material E. There is a mirror plant 1' in System 2 for this.

When you cost Material E in Plant 2 (System 2), you can access the cost component split of Material A in plant 1' by [special procurement key \[Extern\]](#). This enables you to [rollup \[Extern\]](#) the costs for Material A.

You distribute the cost component split by choosing *Accounting* → *Controlling* → *Product Cost Planning* → *Tools* → *Material Costing* → *Distribution* → *Cost Component Split*. You can use the selection criteria, such as material number, class, plant, and costing variant, to define which cost estimates should be distributed to which system.

The system enters the data in Idocs and transfers it to the target system specified. If you do not enter a target system, the selected cost estimates are sent to all the defined receivers in the distribution model.

See also:

Further Costing in Other Systems

- [ALE/Distribution in Product Cost Planning \[Seite 93\]](#)
- [Business Framework Architecture \[Extern\]](#)
- [ALE-Introduction and Overview \[Extern\]](#)

Data Transfer Between Accounting and Logistics Concept (FI/CO-LO)

The distribution is based on the distribution mechanisms described above for accounting systems. The applications in the logistics system pass the documents to an accounting system running in the background that then communicates the information.

Links can be set up between R/3 logistics systems and R/2 or R/3 accounting systems only.

The term "logistics system" here means either a sales and distribution system for a company area or a system that provides materials management, production planning or maintenance functions for a plant.

See also:

[Central Accounting - Decentral Logistics \[Extern\]](#)

[Decentral Accounting - Central Logistics \[Extern\]](#)

[Several Accounting Systems - Several Logistics R/3 Systems \[Extern\]](#)

[Information Flow To The Accounting Department \[Extern\]](#)

[Data Transfer Between Accounting and Logistics \[Extern\]](#)

[Functional Restrictions \[Extern\]](#)

Accounting <-> Human Resources

Accounting <-> Human Resources

For details of ALE business processes between Human Resources Components and Logistics Components see *Human Resources*.

Information systems

This section describes ALE business processes between different R/3 information systems.

Logistics Information Systems

Logistics Information Systems

This scenario supports the distribution of actual data between information systems in logistics.

[Description of the Scenario \[Extern\]](#)

[Prerequisites \[Extern\]](#)

[Structure of IDocs \[Extern\]](#)

[Master Data and Control Data To Be Distributed \[Extern\]](#)

[Initial Data and Synchronization \[Extern\]](#)

Inventory Controlling (LO-LIS, MM-INV)

The scenario supports a central overview of the distributed inventory management (Example: a centralized view of the material stocks).

Logistics data is sent from the decentral inventory management to the central inventory controlling, where it causes the information structures to be updated that SAP has pre-defined for inventory controlling (for example, the characteristic plant and the key figure quantity), but which the customers may modify however they wish.

The central system is frequently only interested in aggregated data (for example, the total stock of a material at a plant rather than a detailed listing for each storage location), and therefore the inventory management data can be summarized.

Restrictions

In the central inventory controlling any of the information structures can be updated according to any sets of rules. Therefore the decentral inventory management has to supply all the logistics data that is available for each action.

Data is always sent for individual documents.

Therefore a scenario containing a worldwide LIS system which has to be supplied with data cannot be implemented using this technique. This requires a general information structure distribution that can exchange summarized data between identical data structures.

The Reference Model

The Reference Model For Inventory Controlling

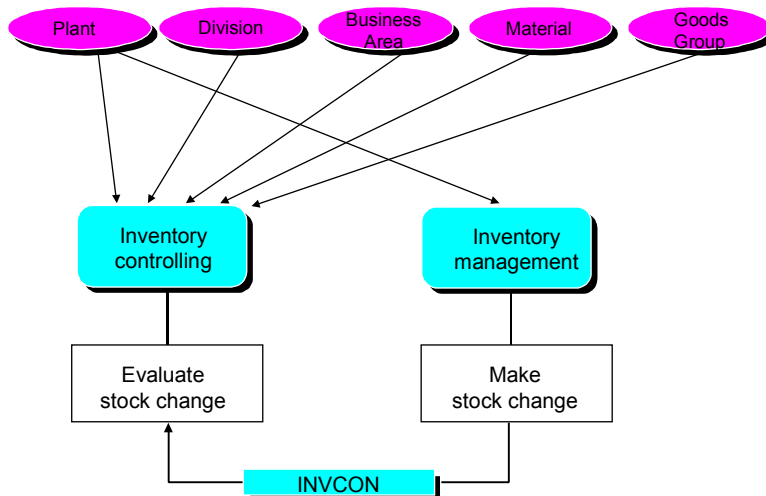

Inventory Controlling (LO-LIS, MM-INV)**Master Data to be Distributed**

The core master data has to be distributed for the following master data:

- Material Master
- Cost centers

Control Data to be Distributed

The control data that has to be distributed for this scenario is detailed in the ALE Implementation Guide.

Initial Download - Synchronization

Inventory controlling includes the following procedures:

- Initial download by setting up statistical data
- Synchronization by making a comparison of stock levels

Purchasing Information System (MM-IS-PU)

A purchasing information system gives an overview of data and processes in purchasing.

This scenario makes this overview possible in distributed purchasing systems also (For example: A central view of release orders on contracts).

Logistics data is sent from the decentral purchasing systems to the central purchasing information system, where it causes information structures to be updated.

Restrictions

In the central purchasing information system any of the information structures can be updated according to any sets of rules. Therefore the decentral purchasing systems have to supply all the logistics data that is available for each action.

Data is always sent for individual documents.

One consequence of this is that there is a very large volume of data traffic, and therefore a significant load on the network.

The Reference Model

The Reference Model for the Purchasing Information System

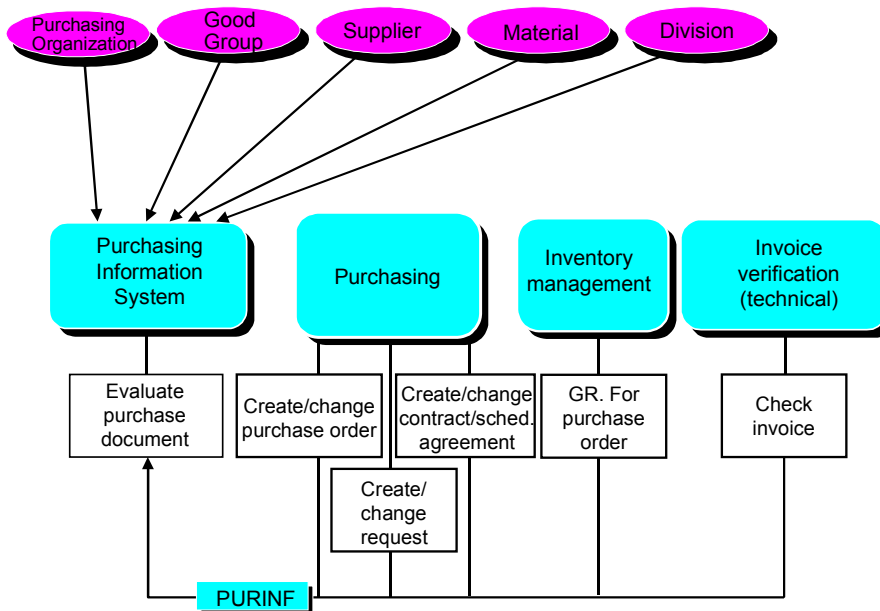

Master Data to be Distributed

The core master data has to be distributed for the following master data:

Purchasing Information System (MM-IS-PU)

- Material Master
- Vendor master records

Control Data to be Distributed

The control data that has to be distributed for this scenario is detailed in the ALE Implementation Guide.

Initial Download and Synchronization

The sales information system includes the following procedures:

- Initial download by setting up statistical data
- Synchronization by making a comparison of stock levels

Sales Information System (SD-IS)

A sales information system gives an overview of data and processes in sales and distribution.

This scenario makes this overview possible in distributed sales and distribution systems also (For example: A central view of orders).

Logistics data is sent from the decentral sales and distribution systems to the central sales information system, where it causes information structures to be updated. The data is usually summarized at this point too.

Restrictions

In the central sales information system any of the information structures can be updated according to any sets of rules. Therefore the decentral sales and distribution systems have to supply all the logistics data that is available for each action.

Data is always sent for individual documents.

One consequence of this is that there is a very large volume of data traffic, and therefore a significant load on the network.

The Reference Model

The Reference Model For The Sales Information System

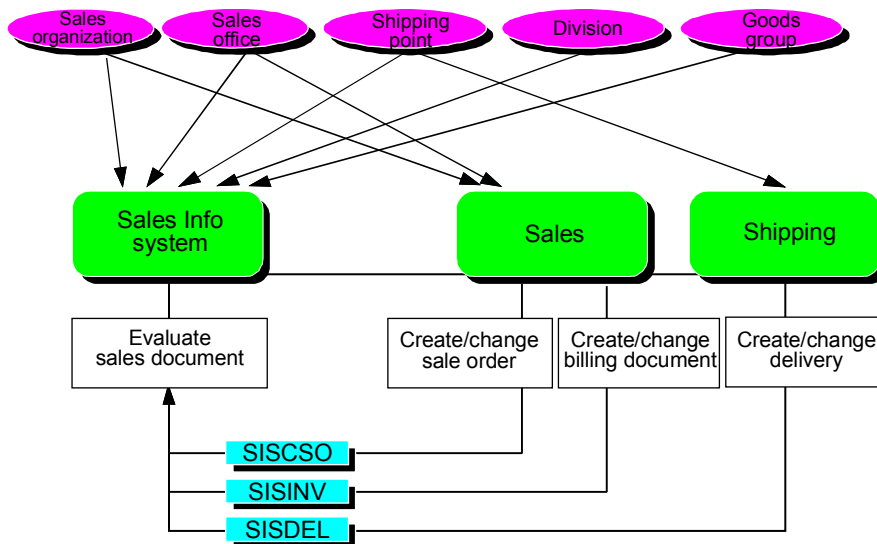

Master Data to be Distributed

The core master data has to be distributed for the following master data:

- Material Master

Sales Information System (SD-IS)

- Customer master records

Control Data to be Distributed

The control data that has to be distributed for this scenario is detailed in the ALE Implementation Guide.

Initial Download and Synchronization

The sales information system includes the following procedures:

- Initial download by setting up statistical data
- Synchronization by making a comparison of stock levels